

# Frequency Converter

EFC 3610 / EFC 5610 Series

Quick Start Guide  
R912005856

Edition 06



## Record of Revision

Edition	Release Date	Notes
DOK-RCON03-EFC-X610***-QU01-EN-P	2014.09	Preliminary
DOK-RCON03-EFC-X610***-QU02-EN-P	2014.11	Added new functions
DOK-RCON03-EFC-X610***-QU03-EN-P	2015.01	Added new functions
DOK-RCON03-EFC-X610***-QU04-EN-P	2015.04	Added new functions
DOK-RCON03-EFC-X610***-QU05-EN-P	2015.07	Added new functions
DOK-RCON03-EFC-X610***-QU06-EN-P	2015.10	Added new functions

## Introduction of this Documentation

This **Quick Start Guide** is derived from the **Operating Instructions** which includes the product data in details.

### **WARNING**

**Personal injury and property damage caused by incorrect application, installation or operation!**

Never work with or control the product before reading through

- **Safety Instructions** in the standard delivery
- Safety descriptions in the **Operating Instructions**

## Reference

For documentation available in other type or language, please consult your local sales partner or check [www.boschrexroth.com/efcx610](http://www.boschrexroth.com/efcx610)

## Copyright

© Bosch Rexroth (Xi'an) Electric Drives and Controls Co., Ltd. 2015

This document, as well as the data, specifications and other information set forth in it, are the exclusive property of Bosch Rexroth (Xi'an) Electric Drives and Controls Co., Ltd. It may not be reproduced or given to third parties without its consent.

## Liability

The specified data is intended for product description purposes only and shall not be deemed to be a guaranteed characteristic unless expressly stipulated in the contract. All rights are reserved with respect to the content of this documentation and the availability of the product.

# Table of Contents

	Page
<b>1 Mechanical Installation.....</b>	<b>1</b>
1.1 Visual Check.....	1
1.2 Ambient Conditions.....	1
1.3 Installation Conditions.....	2
1.4 Figures and Dimensions.....	3
1.4.1 Figures.....	3
1.4.2 Dimensions.....	5
1.4.3 DIN Rail Mounting.....	6
<b>2 Electric Installation.....</b>	<b>7</b>
2.1 Overview of Electric Connections.....	7
2.2 Cable Specifications.....	8
2.2.1 Power Connection.....	8
Cable specification for international without USA / Canada.....	8
Cable specification for USA / Canada.....	10
2.2.2 Control Signal Connection.....	11
2.3 Terminals.....	12
2.3.1 Power Terminals.....	12
2.3.2 Control Terminals.....	13
Control terminals figure.....	13
Control terminals description.....	14
Digital input NPN / PNP wiring.....	16
Digital output DO1a, DO1b load pull-up / pull-down wiring.....	17
Analog input terminals (AI1, AI2, EAI, +10 V, +5 V, Earth and GND)....	18
Relay output terminals.....	19
<b>3 Start-up.....</b>	<b>20</b>
3.1 LED Panel and Dust Cover.....	20
3.1.1 LED Panel.....	20
3.1.2 Dust Cover.....	21
3.1.3 LED Indicator.....	22
3.1.4 Operating Descriptions.....	23
3.2 Start-up Procedure.....	24
3.2.1 Checking before Power-on.....	24
3.2.2 Checking after Power-on.....	24
3.2.3 Checking Start-up Parameters.....	24
3.2.4 Control the Motor.....	26

	Page	
3.2.5	Motor Parameters Auto-Tuning.....	27
3.3	Parameter List.....	30
3.3.1	Terminology and Abbreviation in Parameter List.....	30
3.3.2	Group b: System Parameters.....	30
	b0: Basic system parameters.....	30
3.3.3	Group C: Power Parameters.....	32
	C0: Power control parameters.....	32
	C1: Motor and system parameters.....	34
	C2: V/f control parameters.....	36
	C3*: Vector control parameters.....	37
3.3.4	Group E: Function Control Parameters.....	38
	E0: Set point and control parameters.....	38
	E1: Input terminal parameters.....	41
	E2: Output terminal parameters.....	44
	E3: Multi-speed and simple PLC parameters.....	46
	E4: PID control parameters.....	49
	E5: Extended function parameters.....	50
	E8: Standard communication parameters.....	51
	E9: Protection and error parameters.....	52
3.3.5	Group F0: APP Parameters.....	54
3.3.6	Group H: Extension Card Parameters.....	55
	H0: Extension card general parameters.....	55
	H1: Communication card parameters.....	56
	H8: I/O card parameters.....	58
	H9: Relay card parameters.....	61
3.3.7	Group U: Panel Parameters.....	62
	U0: General panel parameters.....	62
	U1: LED panel parameters.....	62
3.3.8	Group d0: Monitoring Parameters.....	64
<b>4</b>	<b>Diagnosis.....</b>	<b>65</b>
4.1	Display of LED Characters.....	65
4.2	Status Code.....	65
4.3	Warning Code.....	65
4.4	Error Code.....	67

# 1 Mechanical Installation

## 1.1 Visual Check

After unpacking the frequency converter, perform a thorough visual check.

Check the following:

- **The right device has been supplied**
- **The device has no damage**
- **No transport damage such as scratches, cracks or dents**

If you find any deviation from one of the above points, please contact your **Bosch Rexroth** sales partner.

## 1.2 Ambient Conditions

If it is to function perfectly, the frequency converter must be installed in an environment matching the data provided below.

<b>Rated ambient temperature</b>	-10...45 °C
<b>Derating / ambient temperature</b>	1.5 % / 1 °C (45...55 °C)
<b>Rated altitude</b>	≤ 1,000 m
<b>Derating / altitude</b>	1 % / 100 m (1,000...4,000 m)
<b>Relative humidity</b>	≤ 90 % (No condensation)
<b>Degrees of protection</b>	IP 20 (Control cabinet mounting)
<b>Degrees of pollution</b>	2 (EN 50178)

**Tab. 1-1:** Ambient conditions

### 1.3 Installation Conditions

The frequency converter must be installed vertically.

If one frequency converter is arranged above another, make sure the upper limit of air temperature into the inlet is not exceeded (see **"Technical Data"** in the **Operating Instructions**). An air guide is recommended between the frequency converters to prevent the rising hot air being drawn into the upper frequency converter if the upper limit of air temperature is exceeded.

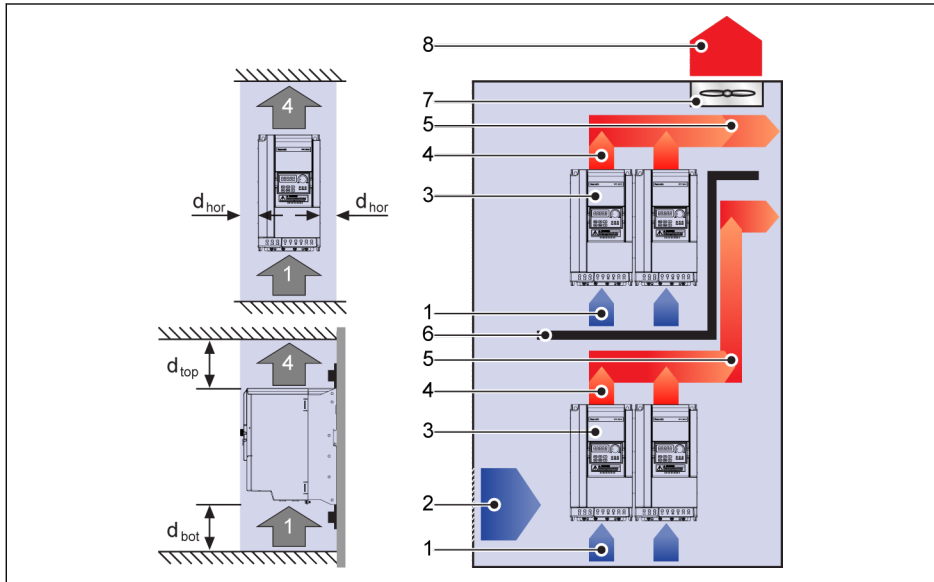

**Fig. 1-1:** Mounting distance and arrangement

$d_{hor}$ : Distance horizontal = 0 mm (0K40...22K0 allows side-by-side mounting)

$d_{top}$ : Minimum top distance = 125 mm

$d_{bot}$ : Minimum bottom distance = 125 mm

- 1: Air inlet at frequency converter
- 2: Air inlet at control cabinet
- 3: Frequency converter
- 4: Air outlet at frequency converter
- 5: Heated air conveying direction
- 6: Air guide in control cabinet
- 7: Fan in control cabinet
- 8: Discharge of heated air

## 1.4 Figures and Dimensions

### 1.4.1 Figures

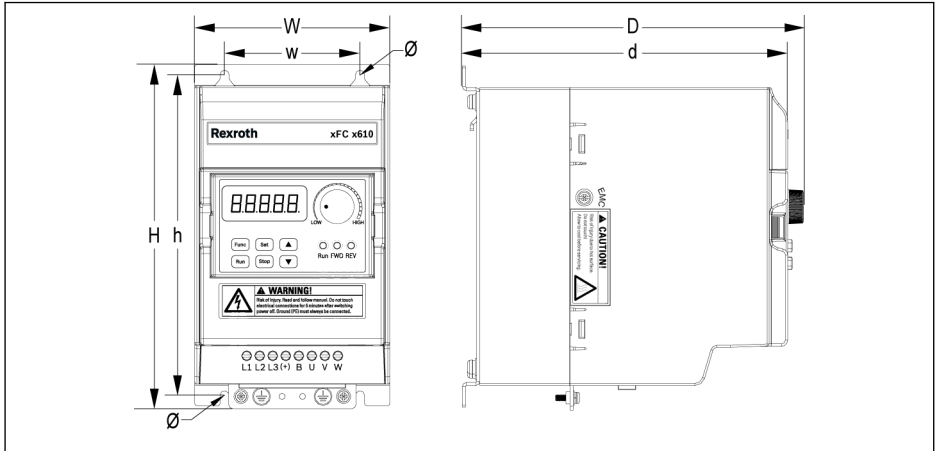

Fig. 1-2: EFC x610 OK40...4K00 dimensions figure

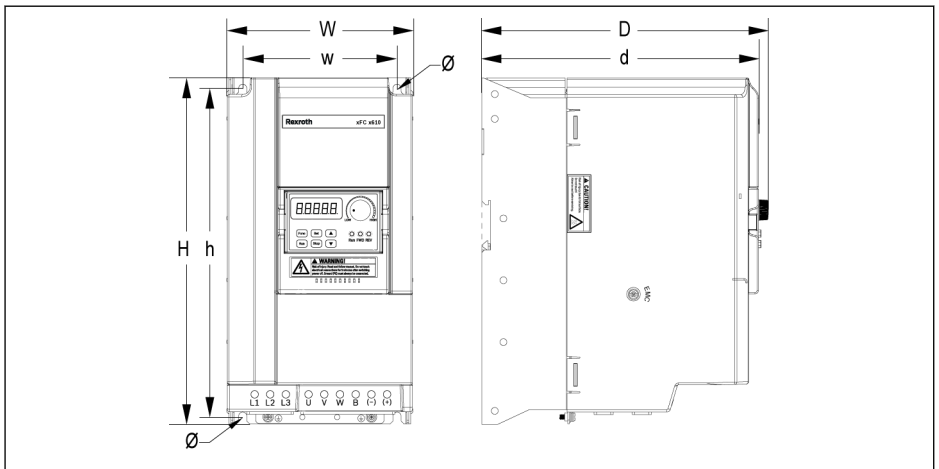
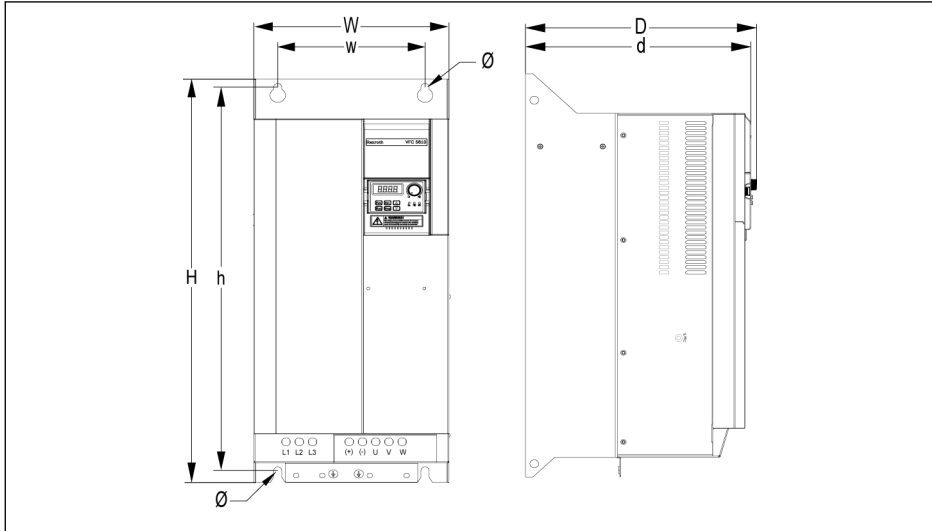

Fig. 1-3: EFC x610 5K50...22K0 dimensions figure



**Fig. 1-4:** EFC 5610 30K0...37K0 dimensions figure



## 1.4.2 Dimensions

Frame	Model <sup>①</sup>	Dimensions [mm]							Screw size <sup>②</sup>	Net weight [kg]
		W	H	D	w	h	d	∅		
B	0K40	95	166	167	66	156	159	4.5	M4	1.5
B	0K75	95	166	167	66	156	159	4.5	M4	1.5
C	1K50	95	206	170	66	196	162	4.5	M4	1.9
D	2K20	120	231	175	80	221	167	4.5	M4	2.6

Tab. 1-2: EFC x610 1P 200 VAC dimensions

Frame	Model <sup>①</sup>	Dimensions [mm]							Screw size <sup>②</sup>	Net weight [kg]
		W	H	D	w	h	d	∅		
B	0K40	95	166	167	66	156	159	4.5	M4	1.5
B	0K75	95	166	167	66	156	159	4.5	M4	1.5
C	1K50	95	206	170	66	196	162	4.5	M4	1.9
C	2K20	95	206	170	66	196	162	4.5	M4	1.9
D	3K00	120	231	175	80	221	167	4.5	M4	2.6
D	4K00	120	231	175	80	221	167	4.5	M4	2.6
E	5K50	130	243	233	106	228	225	6.5	M6	3.9
E	7K50	130	243	233	106	228	225	6.5	M6	4.3
F	11K0	150	283	233	125	265	225	6.5	M6	5.7
F	15K0	150	283	233	125	265	225	6.5	M6	6.4
G	18K5	165	313	241	140	295	233	6.5	M6	8.0
G	22K0	165	313	241	140	295	233	6.5	M6	-
H <sup>③</sup>	30K0	250	510	272	200	492	264	7.0	M6	-
H <sup>③</sup>	37K0	250	510	272	200	492	264	7.0	M6	-

Tab. 1-3: EFC x610 3P 400 VAC dimensions



- <sup>①</sup>: The complete type code for frequency converter is:  
EFCX610-xKxx-xPx-MDA-xx-NNNNN-NNNN, see "**Appendix: Type Coding**" in the **Operating Instructions**.  
E.g., type code for EFC 5610 5K50 (3P 400 VAC model) is:  
EFC5610-5K50-3P4-MDA-7P-NNNNN-NNNN.
- <sup>②</sup>: 4 screws are needed for mounting of EFC x610.
- <sup>③</sup>: **ONLY** available with EFC 5610.

### 1.4.3 DIN Rail Mounting

Besides wall mounting with screws, Frequency Converter EFC x610 also provides DIN rail mounting for models 0K40...7K50.

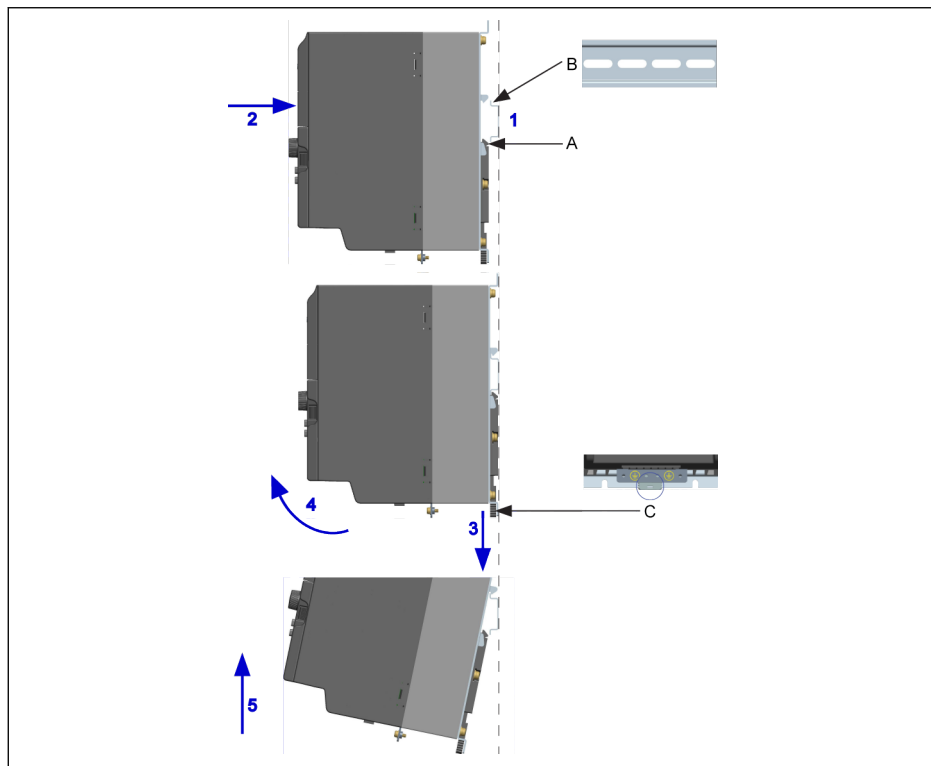

A Mounting buckle  
B Mounting rail

C Disassembly handle

**Fig. 1-5:** DIN rail mounting and disassembly

#### Mounting steps:

- 1: Hold the frequency converter and keep component A and the lower edge of component B at the same position level.
- 2: Push the frequency converter horizontally till a buckle sound indicates a successful mounting.

#### Disassembly steps:

- 3: Pull down component C and hold it.
- 4: Rotate the frequency converter to an appropriate angle as the arrow indicates.
- 5: Lift the frequency converter upwards.

## 2 Electric Installation

### 2.1 Overview of Electric Connections

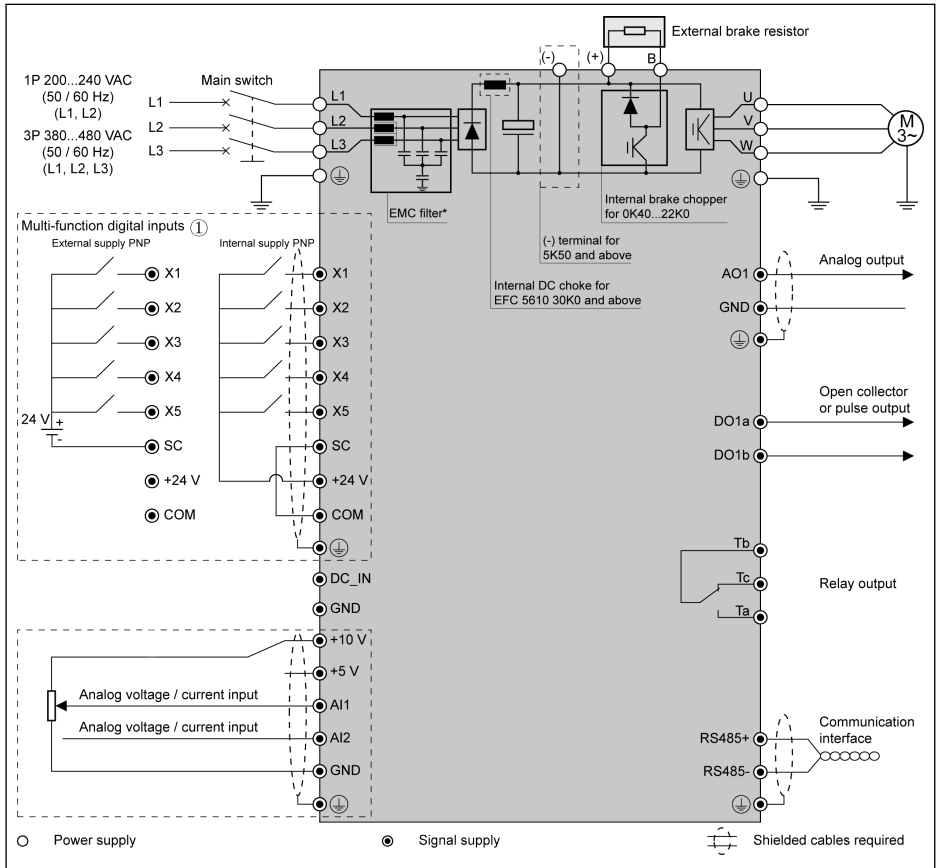

Fig. 2-1: Wiring diagram



- Information on cable size, fuse, screw torque, see **chapter 2.2**.
- Information on terminals, see **chapter 2.3**.
- ①: NPN modes, see **chapter 2.3.2**.
- \*: Can be disconnected by disassembly of a screw. For details, see **Operating Instructions**.
- Pulse input can **ONLY** be set via 'Multi-function digital input X5'.

## 2.2 Cable Specifications

### 2.2.1 Power Connection

#### Cable specification for international without USA / Canada



- **ONLY USE** copper wires of 90 °C or above with XLPE or EPR insulation according to IEC60364-5-52.
- It is recommended to use shielded cables to connect the motor.
- \*: If additional labels available with the terminals of 0K40...7K50, please refer to the torque data on labels.

EFC x610 Model	Fuse (gG)	Power cables installation mode			PE Cable	Torque /Screw
		B1	B2	E		
	[A]	[mm <sup>2</sup> ]	[mm <sup>2</sup> ]	[mm <sup>2</sup> ]	[mm <sup>2</sup> ]	[N·m / lb·in] (Mx)
0K40	10.0	2.5	2.5	2.5	10.0	1.00* / 9.0 (M3)
0K75	16.0	2.5	2.5	2.5	10.0	1.00* / 9.0 (M3)
1K50	25.0	4.0	4.0	2.5	10.0	1.00* / 9.0 (M3)
2K20	32.0	6.0	6.0	4.0	10.0	1.00* / 9.0 (M3)

Tab. 2-1: 1P 200 VAC fuse and cable dimensions for international without USA / Canada

EFC x610 Model	Fuse (gG)	Power cables installation mode			PE Cable	Torque /Screw
		B1	B2	E		
	[A]	[mm <sup>2</sup> ]	[mm <sup>2</sup> ]	[mm <sup>2</sup> ]	[mm <sup>2</sup> ]	[N·m / lb·in] (Mx)
0K40	6.0	2.5	2.5	2.5	10.0	1.00* / 9.0 (M3)
0K75	10.0	2.5	2.5	2.5	10.0	1.00* / 9.0 (M3)
1K50	10.0	2.5	2.5	2.5	10.0	1.00* / 9.0 (M3)
2K20	16.0	2.5	2.5	2.5	10.0	1.00* / 9.0 (M3)
3K00	20.0	4.0	4.0	2.5	10.0	1.00* / 9.0 (M3)
4K00	20.0	4.0	4.0	2.5	10.0	1.00* / 9.0 (M3)
5K50	32.0	6.0	6.0	4.0	10.0	1.20* / 10.5 (M4)
7K50	40.0	6.0	10.0	6.0	10.0	1.20* / 10.5 (M4)
11K0	50.0	10.0	10.0	10.0	10.0	1.76 / 15.6 (M4)
15K0	50.0	10.0	10.0	10.0	10.0	1.76 / 15.6 (M4)
18K5	80.0	25.0	25.0	16.0	16.0	3.73 / 33.0 (M5)
22K0	100.0	25.0	35.0	25.0	25.0	3.73 / 33.0 (M5)

EFC x610 Model	Fuse (gG)	Power cables installation mode			PE Cable	Torque /Screw
		B1	B2	E		
	[A]	[mm <sup>2</sup> ]	[mm <sup>2</sup> ]	[mm <sup>2</sup> ]	[mm <sup>2</sup> ]	[N·m / lb·in] (Mx)
30K0	125.0	35.0	50.0	35.0	25.0	3.80 / 33.6 (M6)
37K0	125.0	35.0	50.0	35.0	35.0	3.80 / 33.6 (M6)

**Tab. 2-2:** 3P 400 VAC fuse and cable dimensions for international without USA / Canada

## Cable specification for USA / Canada



- **ONLY USE** copper wires of 75 °C or above according to UL 508C.
- It is recommended to use shielded cables to connect the motor.
- \*: If additional labels available with the terminals of OK40...7K50, please refer to the torque data on labels.

EFC x610 Model	Fuse (Class J) [A]	Power cables [AWG]	PE Cable [AWG]	Torque /Screw [N·m / lb·in] (Mx)
OK40	10.0	14	8	1.00* / 9.0 (M3)
OK75	15.0	14	8	1.00* / 9.0 (M3)
1K50	25.0	10	8	1.00* / 9.0 (M3)
2K20	30.0	10	8	1.00* / 9.0 (M3)

**Tab. 2-3:** 1P 200 VAC fuse and cable dimensions for USA / Canada

EFC x610 Model	Fuse (Class J) [A]	Power cables [AWG]	PE Cable [AWG]	Torque /Screw [N·m / lb·in] (Mx)
OK40	6.0	14	8	1.00* / 9.0 (M3)
OK75	10.0	14	8	1.00* / 9.0 (M3)
1K50	10.0	14	8	1.00* / 9.0 (M3)
2K20	15.0	14	8	1.00* / 9.0 (M3)
3K00	20.0	12	8	1.00* / 9.0 (M3)
4K00	20.0	12	8	1.00* / 9.0 (M3)
5K50	30.0	10	8	1.20* / 10.5 (M4)
7K50	40.0	8	8	1.20* / 10.5 (M4)
11K0	50.0	8	8	1.76 / 15.6 (M4)
15K0	60.0	6	6	1.76 / 15.6 (M4)
18K5	80.0	4	6	3.73 / 33.0 (M5)
22K0	100.0	2	4	3.73 / 33.0 (M5)
30K0	100.0	2	4	3.80 / 33.6 (M6)
37K0	125.0	1	3	3.80 / 33.6 (M6)

**Tab. 2-4:** 3P 400 VAC fuse and cable dimensions for USA / Canada

## 2.2.2 Control Signal Connection

The following requirements are applicable to signal connection:

- Flexible cables with wire end sleeves
- Cable cross-section: 0.2...1.0 mm<sup>2</sup>
- Cable cross-section for connectors with insulation sleeves: 0.25...1.0 mm<sup>2</sup>
- Analog inputs AI1, AI2, EAI, +10 V, +5 V and GND: use shielded cables
- Digital inputs X1...X5, EX1...EX4, SC, +24 V and COM: use shielded cables
- Analog outputs AO1, EAO and GND: use shielded cables
- RS485 communication: use shielded twisted pair cables



EAI, EX1...EX4 and EAO belong to I/O card.

Recommendations on cable insulation stripping:

Please strip the insulation of control cables according to the dimensions given below. Too long stripping may cause short circuit of adjacent cables; too short stripping may lead to cables becoming loose.

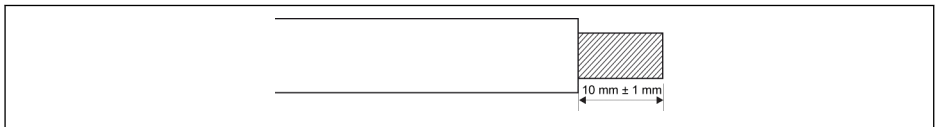

**Fig. 2-2:** Cable insulation stripping length



Please follow the steps below for wiring of control terminals.

- Step 1: Switch off the frequency converter before performing wiring.
- Step 2: Deactivate the control signals in the wiring process.
- Step 3: Switch on the frequency converter.
- Step 4: Set respective parameters.
- Step 5: Activate respective control signals.

## 2.3 Terminals

### 2.3.1 Power Terminals

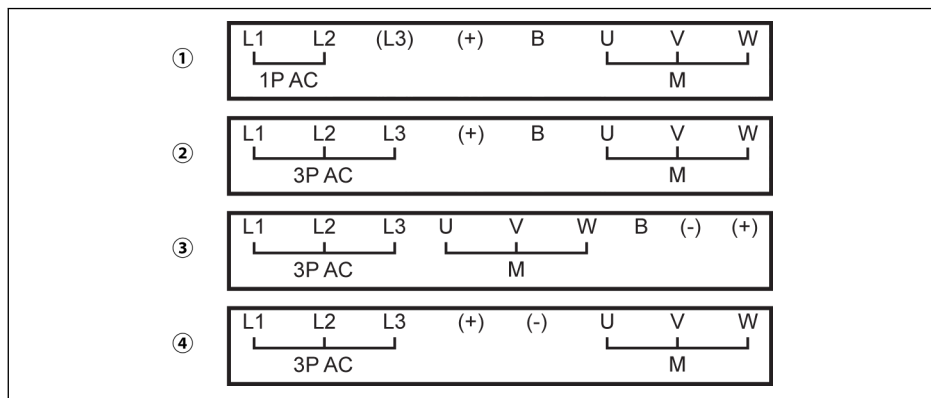

- ① 1P 200 VAC 0K40...2K20
- ② 3P 400 VAC 0K40...4K00
- ③ 3P 400 VAC 5K50...22K0
- ④ 3P 400 VAC 30K0...37K0

**1P AC:** Single phase AC power supply  
**3P AC:** Three phases AC power supply  
**M:** For three phases motor connection

Fig. 2-3: Power terminals

Terminal	Description
L1, L2	Mains supply input terminals
U, V, W	Converter output terminals
B	External brake resistor terminal
(+) ①	DC positive bus terminal

Tab. 2-5: 1P 200 VAC power terminals description

Terminal	Description
L1, L2, L3	Mains supply input terminals
U, V, W	Converter output terminals
B	External brake resistor terminal
(-) ①	DC negative bus terminal (only available with models of 5K50 and above)
(+) ①	DC positive bus terminal

Tab. 2-6: 3P 400 VAC power terminals description

### **⚠ WARNING**

①: Detailed descriptions on (-) and (+) in the **Operating Instructions** must be read through and followed before any operation on these two terminals.



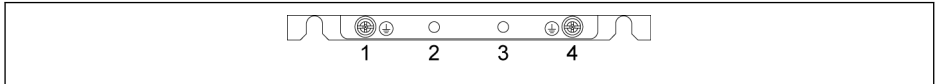

Fig. 2-4: Grounding and PE terminals

1. Grounding terminal for mains cables
2. Reserved for PE / shielding adapter (Order additionally)
3. Reserved for PE / shielding adapter (Order additionally)
4. Grounding terminal for motor cables

## 2.3.2 Control Terminals

### Control terminals figure

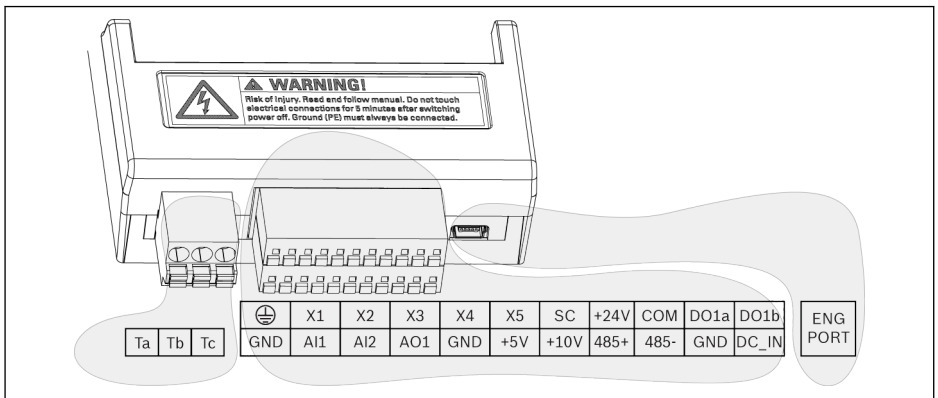

Fig. 2-5: Control circuit terminals

### ⚠ CAUTION

The frequency converter might be damaged!

Please make sure that the power supply of the frequency converter has been switched off before plugging or unplugging the connector.



The terminal block is **ONLY** for wiring convenience, which **CANNOT** be used for fixing the cables. Additional measures need to be taken by users for cable fixing purpose.

## Control terminals description

### Digital inputs

Terminal	Signal function	Description	Signal requirement
X1...X5	Multi-function digital inputs	See Group E1	Inputs via opto-electric couplers: 24 VDC, 8 mA / 12 VDC, 4 mA Pulse input: Max. 50.0 kHz
X5 (multiplex)	Pulse input		
SC	Shared connection	Shared connection for isolation opto-electric couplers	–
+24 V	Power supply for digital inputs	COM is reference	Max. output current: 100 mA
COM		Isolated from GND	

### Analog inputs

Terminal	Signal function	Description	Signal requirement
+10 V	Power supply for analog inputs	GND is reference	Max. output current: 30 mA
+5 V			Max. output current: 10 mA
AI1	Analog voltage input 1/ Analog current input 1	Analog voltage / current inputs are used as external frequency setting channels  To switch between voltage and current or to set the input related functions, see Group E1	Voltage input range: 0/2...10 V Input impedance: 40 k $\Omega$ Resolution: 1/1,000 Current input range: 0/4...20 mA Input impedance: 500 $\Omega$ Resolution: 1/1,000
AI2	Analog voltage input 2/ Analog current input 2		
GND	Shared connection	Isolated from COM	–
	Shielding connection	Connected with grounding terminals on heatsink internally	–

**Digital outputs**

Terminal	Signal function	Description	Signal requirement
DO1a	Open collector output or pulse output	See Group E2 COM is reference	Open collector output: Max. 30 VDC, 50 mA Pulse output Max. frequency: 32.0 kHz
DO1b			
Ta	Relay changeover contacts	See Group E2	Rated capacity: 250 VAC, 3 A; 30 VDC, 3 A
Tc			
Tb			

**Analog outputs**

Terminal	Signal function	Description	Signal requirement
AO1	Analog output	See Group E2	Voltage output: 0...10 V Maximum load current for voltage output: 5 mA Current output: 0...20 mA Maximum load resistance for current output: 332 Ω
GND	Shared connection	Isolated from COM	–

**Modbus communication**

Terminal	Signal function	Description	Signal requirement
485+	Positive differential signal	GND is reference	–
485-	Negative differential signal		

**External control power supply**

Terminal	Signal function	Description	Signal requirement
DC_IN	Auxiliary power supply for control board	External +24 V supply input for control and panel boards ( <b>NOT</b> used for digital inputs)	Rated capacity: 24 V (-10...+15 %) 200 mA
GND	Shared connection	Isolated from COM	–

### Digital input NPN / PNP wiring

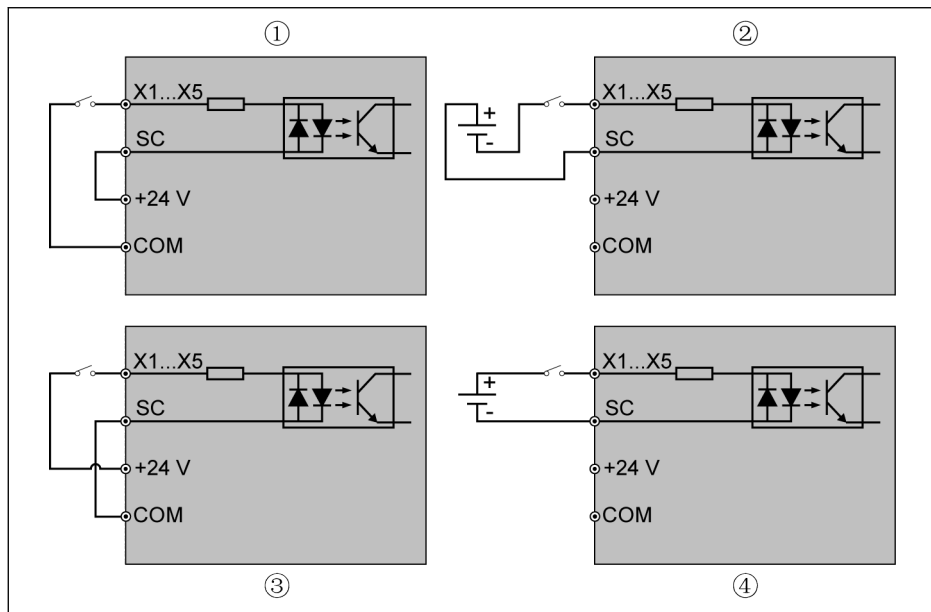

- ① NPN wiring with internal power supply
- ② NPN wiring with external power supply

- ③ PNP wiring with internal power supply
- ④ PNP wiring with external power supply

**Fig. 2-6:** Digital input NPN / PNP wiring

## Digital output DO1a, DO1b load pull-up / pull-down wiring

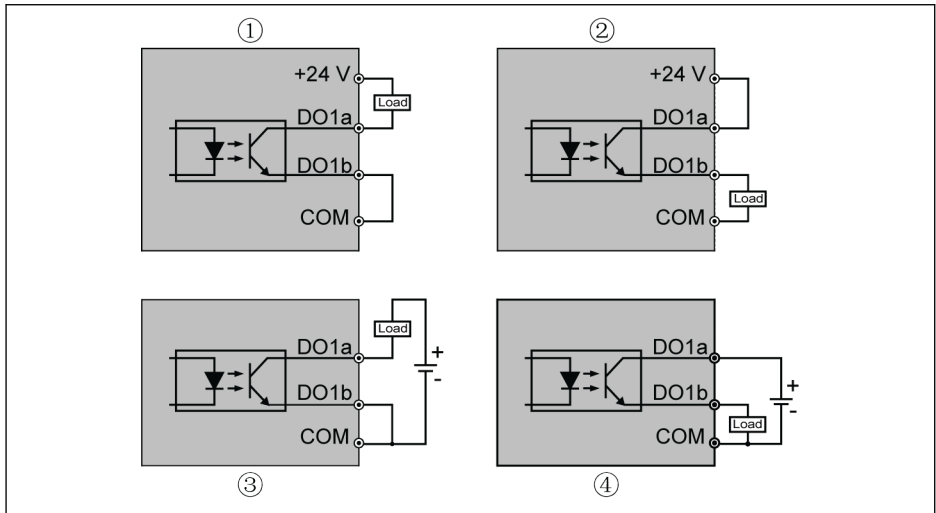

- ① Load pull-up wiring with internal power supply
- ② Load pull-down wiring with internal power supply
- ③ Load pull-up wiring with external power supply
- ④ Load pull-down wiring with external power supply

**Fig. 2-7:** Digital output DO1a, DO1b load pull-up / pull-down wiring

- For internal supply, **ONLY USE** terminal +24 V and **NEVER USE** terminal +10 V or +5 V!
- For external supply, its reference ground **MUST** be connected to terminal COM!

### Analog input terminals (AI1, AI2, EAI, +10 V, +5 V, Earth and GND)

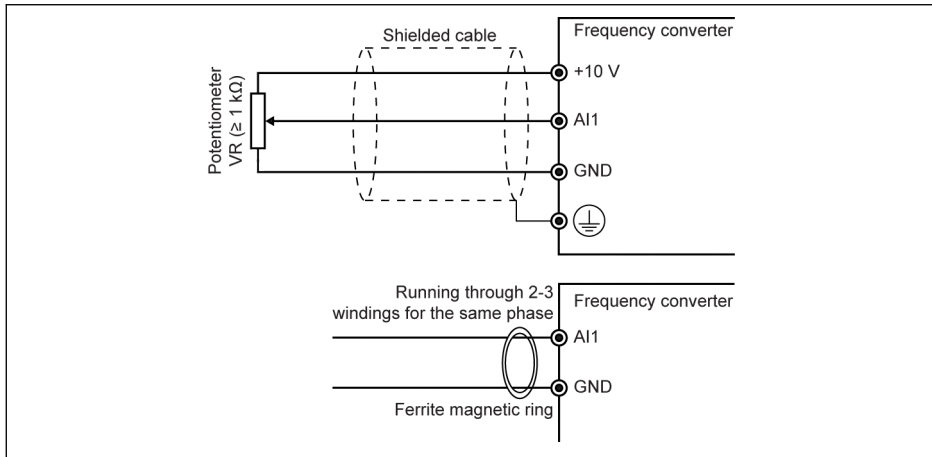

Fig. 2-8: Analog input terminals



- The figure for AI2 and +5 V is similar as the above figure.
- Incorrect operation may occur due to interference on the analog signal. In such cases, connect a ferrite magnetic ring at the input side of the analog signal, as shown above.
- The above figure is also valid for analog input EAI on I/O card.

## Relay output terminals

When relay output terminals are connected with inductive loads (relays, contactors, solenoid valves, motors, etc.), following noise suppression circuits need to be applied at the coils of the inductive loads, as close as possible to the inductive loads, in order to reduce the electromagnetic interference generated from inductive load action.

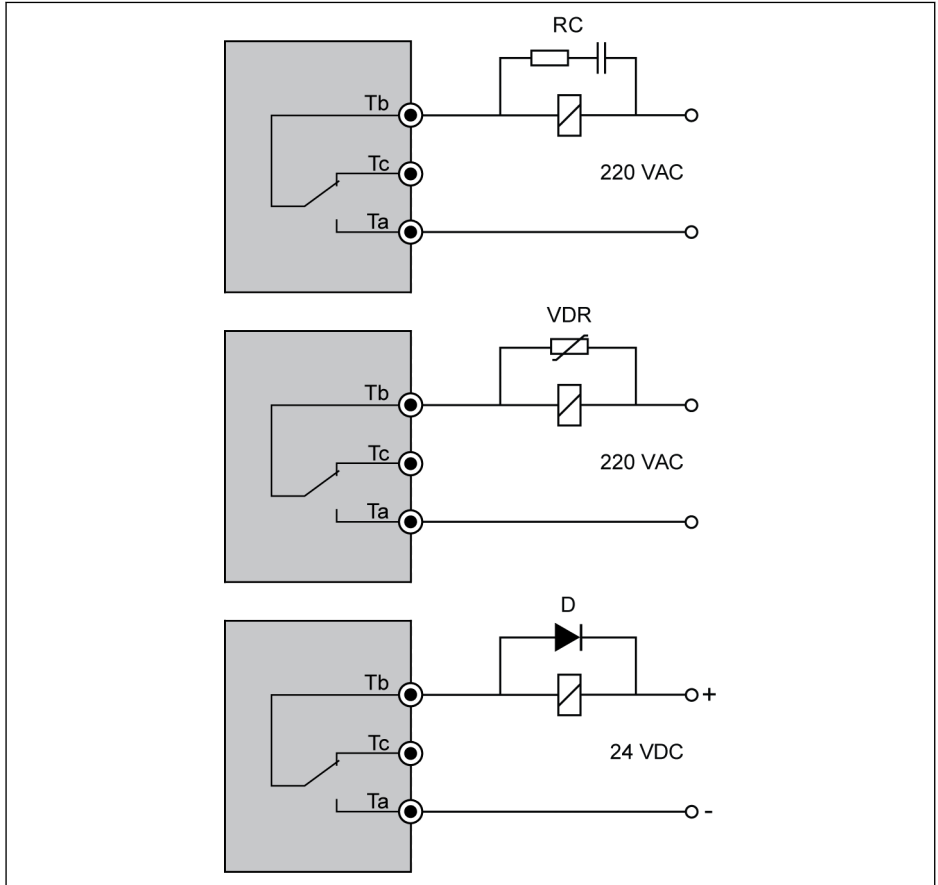

**Tb** Shared terminal  
**Tc** Normally closed contact  
**Ta** Normally open contact

**RC** RC filtering  
**VDR** Varistor  
**D** Diode

**Fig. 2-9:** Noise suppression circuits for relay output terminals

## 3 Start-up

### 3.1 LED Panel and Dust Cover

#### 3.1.1 LED Panel

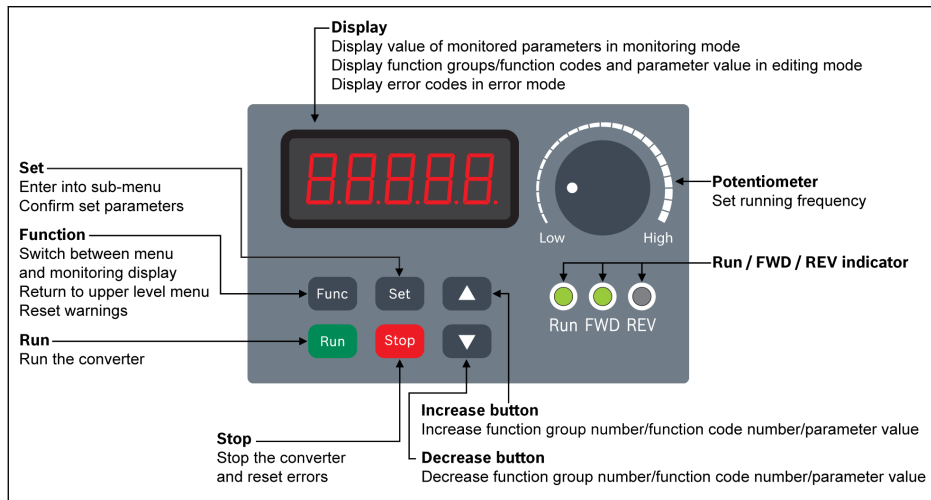

Fig. 3-1: LED panel



### 3.1.2 Dust Cover

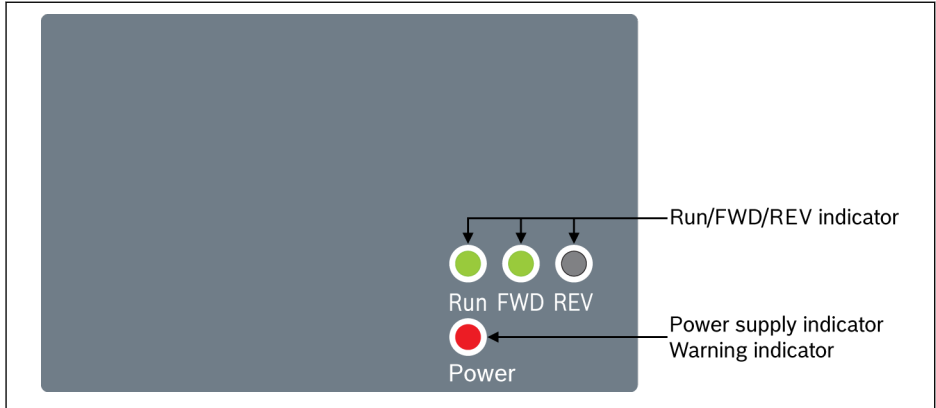

Fig. 3-2: Dust cover



Frequency Converter EFC x610 are available with **Dust Cover** instead of **LED Panel** on demand. To operate frequency converters with **Dust Cover**,

- Order one **LED Panel** additionally, and then set the frequency converters with **Parameter replication** function. See parameter b0.11.

### 3.1.3 LED Indicator

Mode	Run	FWD	REV	Power <sup>①</sup>
Power off	Off	Off	Off	Off
Ready	Off	Green / Off	Off / Green	Red
Run (FWD)	Green	Green	Off	Red
Run (REV)	Green	Off	Green	Red
Run pending	Blinks in green			
DC-braking at start	(Short green	Green / Off	Off / Green	Red
Direction change dead time	long dark)			
Deceleration stop phase	Blinks in green			
DC-braking at stop	(Short dark	Green / Off	Off / Green	Red
	long green)			
Warning with FWD	Green	Green	Off	Blinks in red (Short dark long red)
Warning with REV	Green	Off	Green	Blinks in red (Short dark long red)
Warning at stop	Off	Green / Off	Off / Green	Blinks in red (Short dark long red)
Error	Off	Green / Off	Off / Green	Blinks in red (Short red long dark)

Tab. 3-1: LED indicator status



- <sup>①</sup>: Available on dust cover or when neither the LED panel nor the dust cover is installed.
- The frequency converter stops if FWD and REV commands are active at the same time.

### 3.1.4 Operating Descriptions

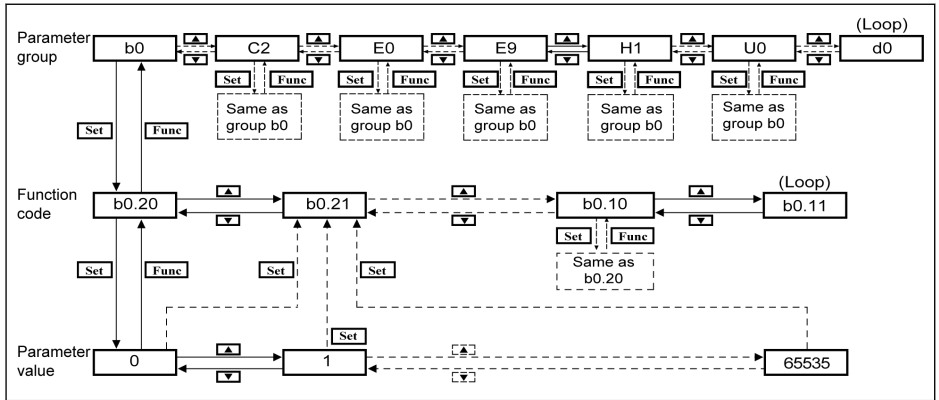

Fig. 3-3: Operating mode

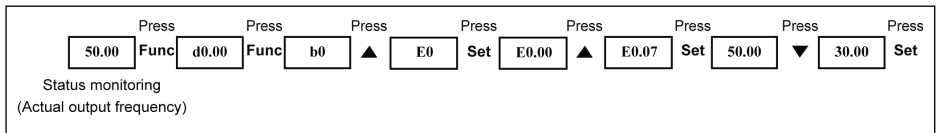

Fig. 3-4: Operating example



**Digit Shifting Function** is provided for fast parameter selection and modification. Please refer to the **Operating Instructions** for details.

## 3.2 Start-up Procedure

### 3.2.1 Checking before Power-on

<b>Ambient conditions</b>	See <a href="#">chapter 1.2 "Ambient Conditions" on page 1</a>
<b>Installation conditions</b>	See <a href="#">chapter 1.3 "Installation Conditions" on page 2</a> See <a href="#">chapter 2 "Electric Installation" on page 7</a>
<b>Wiring</b>	EMC requirements must be observed, see details in <b>Operating Instructions</b> All switches must be switched off All loads must be disconnected

Tab. 3-2: Checking before Power-on

### 3.2.2 Checking after Power-on

<b>LED panel</b>	0.00 is displayed
<b>Dust cover</b>	Power indicator is red, see <a href="#">chapter 3.1.2 "Dust Cover" on page 21</a> and <a href="#">chapter 3.1.3 "LED Indicator" on page 22</a>

Tab. 3-3: Checking after Power-on

### 3.2.3 Checking Start-up Parameters

Set [b0.00] = '3: Start-up parameters', and then check all start-up parameters. For terminology and abbreviation in the above table, see [chapter 3.3.1 "Terminology and Abbreviation in Parameter List" on page 30](#).

Code	Name	Setting range	Default	Min.	Attri.
C0.05	Carrier frequency	DOM	DOM	1	Run
C1.05	Motor rated power	0.1...1,000.0 kW	DOM	0.1	Stop
C1.06	Motor rated voltage	0...480 V	DOM	1	Stop
C1.07	Motor rated current	0.01...655.00 A	DOM	0.01	Stop
C1.08	Motor rated frequency	5.00...400.00 Hz	50.00	0.01	Stop
C1.09	Motor rated speed	1...30,000 rpm	DOM	1	Stop
C2.00	V/f curve mode	0: Linear	0	-	Stop
		1: Square			
		2: User-defined			
E0.00	First frequency setting source	0...21	0	-	Stop
E0.01	First run command source	0...2	0	-	Stop
E0.07	Digital setting frequency	0.00...[E0.09] Hz	50.00	0.01	Run
E0.08	Maximum output frequency	50.00...400.00 Hz	50.00	0.01	Stop
E0.09	Output frequency high limit	[E0.10]...[E0.08] Hz	50.00	0.01	Run
E0.10	Output frequency low limit	0.00...[E0.09] Hz	0.00	0.01	Run

Code	Name	Setting range	Default	Min.	Attri.
E0.17	Direction control	0: Forward/Reverse	0	-	Stop
		1: Forward only			
		2: Reverse only			
		3: Swap default direction			
E0.25	Acceleration / Deceleration curve mode	0: Linear mode 1: S-curve	0	-	Stop
E0.26	Acceleration time	0.1...6,000.0 s	DOM	0.1	Run
E0.27	Deceleration time	0.1...6,000.0 s	DOM	0.1	Run
E0.35	Start mode	0: Start directly	0	-	Stop
		1: DC-braking before start			
		2: Start with speed capture			
E0.50	Stop mode	3: Automatic start / stop according to setting frequency	0	-	Stop
		0: Decelerating stop			
		1: Freewheeling stop 1			
		2: Freewheeling stop 2			

**Tab. 3-4:** Start-up parameters

### 3.2.4 Control the Motor

Step	Operation	Description
1	Rotate the potentiometer counterclockwise (leftwards) to the greatest extent	Output frequency setting is 0.00
2	Press <Run> button	Control command active, 0.00 is displayed
3	Rotate the potentiometer clockwise (rightwards) slowly and till 5.00 is displayed	The motor starts to run
	<b>Observe the running status:</b>	<b>Recommended operation:</b>
	If the motor runs in the correct direction If the motor runs steadily If there is any abnormal noise or problem	Stop the motor immediately by switching off the power if any abnormality occurs Restart commissioning only after error causes have been removed
4	Rotate the potentiometer clockwise	The motor accelerates
5	Rotate the potentiometer counterclockwise	The motor decelerates
6	Press <Stop> button	Stop command active, the motor stops
7	Check parameters without load	Settings according to actual applications
8	Check parameters with load	Settings according to actual applications

**Tab. 3-5:** Motor controlling procedure

- EFC x610 has no internal contactor, and will be energized once the power supply is connected. When the **Run** button is pressed down (or 'Control by terminals' is activated), the frequency converter will generate output.
- By default, EFC x610 is set as:
  - The frequency converter is started or stopped by the operating panel control.
  - The output frequency is set by the potentiometer on the operating panel.
- After powering on, please confirm:
  - The setting frequency is displayed (no error display).
  - The monitoring parameter is consistent with the actual situation.
- By default, the frequency converter displays **Output frequency** in run status and **Setting frequency** in stop status as the monitoring parameters. You may change them to other parameters as described in parameters U1.00 and U1.10. The factory defaults are based on standard applications with standard motors.



For frequency converters with dust cover, it is recommended to install an LED panel to perform the above operations.

### 3.2.5 Motor Parameters Auto-Tuning

#### The application with asynchronous motor(ASM)

When SVC control is used or in the condition of V/f control demanding for higher control performance, motor parameter auto-tuning is necessary. Two modes of auto-tuning are available, static auto-tuning and rotational auto-tuning. The former mode is mainly used for V/f control and the latter is used **mainly** for SVC control.

Check and make sure the following points before auto-tuning:

- The motor is in standstill and not at high temperature.
- The power rating of the frequency converter is close to that of the motor.
- Set C1.05...C1.10 based on motor nameplate data. If the power factor data is unavailable on the nameplate, keep the default setting of C1.10.
- Set E0.08 according to motor parameters and actual application conditions.



Disconnect the load from the motor shaft for rotational auto-tuning.

Set auto-tuning mode and start motor parameter auto-tuning:

Set the following parameter according to the control mode of the frequency converter and the application situation.

Code	Name	Setting range	Default	Min.	Attri.
C1.01	Motor parameter tuning	0...2	0	-	Stop

- 0: Inactive. The auto-tuning function is by default inactive.
- 1: Static auto-tuning. This mode is suggested to be used for V/f control. It can also be used for SVC control when the load cannot be disconnected.
- 2: Rotational auto-tuning (suggested to be used for SVC control)

Press the **<Run>** button on the operating panel to start auto-tuning. In the process of auto-tuning, a status code 'tUnE' will be displayed on the operating panel. When the auto-tuning process is complete, the status code disappears and the settings of the following parameters will be obtained automatically:

Static auto-tuning	Rotational auto-tuning	Parameters obtained by auto-tuning
√	√	C1.12: Motor rated slip frequency
-	√	C1.13: Motor inertia mantissa <sup>①</sup>
-	√	C1.14: Motor inertia exponent <sup>①</sup>
√	√	C1.20: Motor no-load current
√	√	C1.21: Stator resistance
√	√	C1.22: Rotor resistance
√	√	C1.23: Leakage inductance
√	√	C1.24: Mutual inductance

Static auto-tuning	Rotational auto-tuning	Parameters obtained by auto-tuning
-	√	C3.00: Speed loop proportional gain
-	√	C3.01: Speed loop integral time
√	√	C3.05: Current loop proportional gain
√	√	C3.06: Current loop integral time

Tab. 3-6: Parameters obtained by auto-tuning



①: Only applicable for EFC 5610.

### The application with permanent magnetized synchronous motor (PMSM)

When SVC control is used for the control of PMSM, motor parameters auto-tuning function shall be adopted. Two modes of auto-tuning are available, i.e. static auto-tuning and rotational auto-tuning.

Before running parameter auto-tuning on synchronous motor, make sure to set both motor type C1.00 and motor nameplate parameters correctly.

Check and make sure the following points before auto-tuning:

- The motor is in standstill and not at high temperature.
- The power rating of the frequency converter is close to that of the motor.
- Set C1.05, C1.07, C1.09, C1.11 based on motor nameplate data.
- Set E0.08, E0.09 according to motor parameters and actual application conditions.



Disconnect the load from the motor shaft for rotational auto-tuning.

Set auto-tuning mode and start motor parameter auto-tuning:

Set the following parameter according to the control mode of the frequency converter and the application situation:

Code	Name	Setting range	Default	Min.	Attri.
C1.01	Motor parameter tuning	0...2	0	-	Stop

- 0: Inactive  
It's recommended to run static auto-tuning or rotational auto-tuning for PMSM.
- 1: Static auto-tuning  
Static auto-tuning shall be used when the motor load is not removable. It's necessary to input inertia value manually in order to achieve the best control effect.
- 2: Rotational auto-tuning



In condition the motor load is removable, it's recommended to move the load and the motor away and run rotational auto-tuning. This method allows the acquisition of all the motor and control parameters that are needed for the vector control and thus enable the best vector control effect.

Press the **<Run>** button on the operating panel when the setting is finished for auto-tuning. In the process of auto-tuning, a status code 'tUnE' will be displayed on the operating panel. When the auto-tuning process is completed, the status code disappears and the settings of the following parameters will be obtained automatically:

Static auto-tuning	Rotational auto-tuning	Parameters obtained by auto-tuning
-	√	C1.13: Motor inertia mantissa
-	√	C1.14: Motor inertia exponent
√	√	C1.20: Motor no-load current
√	√	C1.21: Stator resistance
√	√	C1.23: Leakage inductance
√	√	C3.05: Current loop proportional gain
√	√	C3.06: Current loop integral time
-	√	C3.00: Speed loop proportional gain
-	√	C3.01: Speed loop integral time

**Tab. 3-7:** Parameters obtained by auto-tuning

## 3.3 Parameter List

### 3.3.1 Terminology and Abbreviation in Parameter List

- **Code:** Function / parameter code, written in bx.xx, Cx.xx, Ex.xx, Hx.xx, Ux.xx, dx.xx
- **Name:** Parameter name
- **Default:** Factory default
- **Min.:** Minimum setting step
- **Attri.:** Parameter attribute
  - **Run:** Parameter setting can be modified when the converter is in run or stop status.
  - **Stop:** Parameter setting can only be modified when the converter is in stop status.
  - **Read:** Parameter setting is read-only and cannot be modified.
- **DOM:** Depends on model
- **[bx.xx], [Cx.xx], [Ex.xx], [Hx.xx], [Ux.xx], [dx.xx]:** Function / parameter values

### 3.3.2 Group b: System Parameters

#### b0: Basic system parameters

Code	Name	Setting range	Default	Min.	Attri.
b0.00	Access authority setting	0: Basic parameters 1: Standard parameters 2: Advanced parameters 3: Start-up parameters 4: Modified parameters	0	–	Run
b0.09	Parameter initialization setting	1: Base device and non Fieldbus options 2: Fieldbus options 3: Base device, non Fieldbus and Fieldbus options	1	–	Stop
b0.10	Parameter initialization	0: Inactive 1: Restore to default settings 2: Clear error record	0	–	Stop
b0.11	Parameter copy	0: Inactive 1: Backup parameters to panel 2: Restore parameters from panel	0	–	Stop

Code	Name	Setting range	Default	Min.	Attri.
b0.12	Parameter set selection	0: Parameter set 1 active 1: Parameter set 2 active	0	-	Stop
b0.20	User password	0...65,535	0	1	Run
b0.21	Manufacturer password	0...65,535	0	1	Stop

### 3.3.3 Group C: Power Parameters

#### C0: Power control parameters

Code	Name	Setting range	Default	Min.	Attri.
C0.00	Control mode (EFC 5610 only)	0: V/f control 1: Sensorless vector control	0	-	Stop
C0.01	Normal / Heavy duty setting <sup>①</sup>	0: ND (Normal duty) 1: HD (Heavy duty)	1	-	Stop
C0.05	Carrier frequency	DOM	DOM	1	Run
C0.06	Carrier frequency automatic adjustment	0: Inactive 1: Active	1	-	Stop
C0.15	Brake chopper start voltage	1P 200 VAC: 300...390 V	385	1	Stop
		3P 400 VAC: 600...785 V	770		
C0.16	Brake chopper duty cycle	1...100 %	100	1	Stop
C0.25	Overvoltage prevention mode	0...3	3	-	Stop
C0.26	Stall overvoltage prevention level	1P 200 VAC: 300...390 V	385	1	Stop
		3P 400 VAC: 600...785 V	770		
C0.27	Stall overcurrent prevention level <sup>②</sup>	20.0 %...[C2.42]	150.0	0.1	Stop
C0.28	Phase loss protection mode	0...3	3	-	Run
C0.29	Converter overload pre-warning level	20.0...200.0 %	110.0	0.1	Stop
C0.30	Converter overload pre-warning delay	0.0...20.0 s	2.0	0.1	Stop
C0.40	Power loss ride-through mode	0: Inactive 1: Output disable 2: Regain kinetic energy	0	-	Stop
C0.50	Fan control	0: Automatically controlled 1: Always on	0	-	Run
C0.51	Fan total running time	0...65,535 h	0	1	Read
C0.52	Fan maintenance time	0...65,535 h (0: Inactive)	0	1	Stop
C0.53	Fan total running time reset	0: Inactive 1: Active Resets to '0' after action is executed	0	-	Run

<sup>①</sup>: this parameter is only available with models of 5K50 and above.

<sup>②</sup>: percentage of frequency converter rated current.

**Setting range of C0.25:**

0: Both disabled

1: Stall overvoltage protection enabled, resistor braking disabled

2: Stall overvoltage protection disabled, resistor braking enabled

3: Stall overvoltage protection enabled, resistor braking enabled

**Setting range of C0.28:**

0: Both input and output phase loss protection active

1: Only input phase loss protection active

2: Only output phase loss protection active

3: Both input and output phase loss protection inactive

## C1: Motor and system parameters

Code	Name	Setting range	Default	Min.	Attri.
C1.00	Motor type	0: Asynchronous motor 1: Synchronous motor (only for EFC 5610)	0	-	Stop
C1.01	Motor parameter tuning	0: Inactive 1: Static auto-tuning 2: Rotational auto-tuning <sup>①</sup>	0	-	Stop
C1.05	Motor rated power	0.1...1,000.0 kW	DOM	0.1	Stop
C1.06	Motor rated voltage	0...480 V	DOM	1	Stop
C1.07	Motor rated current	0.01...655.00 A	DOM	0.01	Stop
C1.08	Motor rated frequency	5.00...400.00 Hz	50.00	0.01	Stop
C1.09	Motor rated speed	1...30,000 rpm	DOM	1	Stop
C1.10	Motor rated power factor	0.00: Automatically identified 0.01...0.99: Power factor setting	0.00	0.01	Stop
C1.11	Motor poles <sup>①</sup>	2...128	DOM	1	Stop
C1.12	Motor rated slip frequency	0.00...20.00 Hz	DOM	0.01	Run
C1.13	Motor inertia mantissa <sup>①</sup>	1...5,000	DOM	1	Stop
C1.14	Motor inertia exponent <sup>①</sup>	0...7	DOM	1	Stop
C1.15	Motor torque constant	0.01...200	DOM	0.01	Run
C1.20	Motor no-load current	0.00...[C1.07] A	DOM	0.01	Stop
C1.21	Stator resistance	0.00...50.00 Ω	DOM	0.01	Stop
C1.22	Rotor resistance	0.00...50.00 Ω	DOM	0.01	Stop
C1.23	Leakage inductance	0.00...200.00 mH	DOM	0.01	Stop
C1.24	Mutual inductance	0.0...3,000.0 mH	DOM	0.1	Stop
C1.69	Motor thermal model protection setting	0: Inactive 1: Active	1	-	Stop
C1.70	Motor overload pre-warning level	100.0...250.0 %	100.0	0.1	Run
C1.71	Motor overload pre-warning delay	0.0...20.0 s	2.0	0.1	Run
C1.72	Motor thermal sensor type	0: PTC; 2: PT100	0	-	Stop
C1.73	Motor thermal sensor protection level	0.0...10.0	2.0	0.1	Stop
C1.74	Motor thermal model protection time constant	0.0...400.0 min	DOM	0.1	Stop

Code	Name	Setting range	Default	Min.	Attri.
C1.75	Low speed derating frequency	0.10...300.00 Hz	25.00	0.01	Run
C1.76	Zero speed load	25.0...100.0 %	25.0	0.1	Run



ⓘ: **ONLY** for EFC 5610, and motor load must be decoupled before rotational auto-tuning.

## C2: V/f control parameters

Code	Name	Setting range	Default	Min.	Attri.
C2.00	V/f curve mode	0: Linear 1: Square 2: User-defined	0	-	Stop
C2.01	V/f frequency 1	0.00...[C2.03] Hz	0.00	0.01	Stop
C2.02	V/f voltage 1 <sup>①</sup>	0.0...120.0 %	0.0	0.1	Stop
C2.03	V/f frequency 2	[C2.01]...[C2.05] Hz	0.00	0.01	Stop
C2.04	V/f voltage 2 <sup>①</sup>	0.0...120.0 %	0.0	0.1	Stop
C2.05	V/f frequency 3	[C2.03]...[E0.08] Hz	50.00	0.01	Stop
C2.06	V/f voltage 3 <sup>①</sup>	0.0...120.0 %	100.0	0.1	Stop
C2.07	Slip compensation factor	0...200 %	0	1	Run
C2.21	Torque boost setting	0.0 %: Automatic boost 0.1...20.0 %: Manual boost	0.0	0.1	Run
C2.22	Automatic torque boost factor	0...320 %	50	1	Run
C2.23	Heavy load stabilization setting	0: Inactive 1: Active	1	-	Run
C2.24	Light load oscillation damping factor	0...5,000 %	0	1	Run
C2.25	Light load oscillation damping filter factor	10...2,000 %	100	1	Run
C2.40	Current limitation mode	0: Always inactive 1: Inactive at constant speed 2: Active at constant speed	2	-	Stop
C2.42	Current limitation level <sup>②</sup>	[C0.27]...250 %	150	1	Stop
C2.43	Current limitation proportional gain	0.000...10.000	DOM	0.001	Stop
C2.44	Current limitation integral time	0.001...10.000	DOM	0.001	Stop

①: percentage of motor rated voltage [C1.06].

②: percentage of frequency converter rated current.



**C3\*: Vector control parameters**

Code	Name	Setting range	Default	Min.	Attri.
C3.00	Speed loop proportional gain	0.00...655.35	DOM	0.01	Run
C3.01	Speed loop integral time	0.01...655.35 ms	DOM	0.01	Run
C3.05	Current loop proportional gain	0.1...1,000.0	DOM	0.1	Run
C3.06	Current loop integral time	0.01...655.35 ms	DOM	0.01	Run
C3.20	Low speed torque limitation	1...200 %	100	1	Stop
C3.40	Torque control mode	0: Activated by digital inputs 1: Always active	0	-	Stop
C3.41	Torque reference channel	0: AI1 analog input 1: AI2 analog input 2: Panel potentiometer 3: EAI analog input 99: Inactive	0	-	Stop
C3.42	Torque reference minimum value <sup>①</sup>	0.0 %...[C3.43]	0.0	0.1	Run
C3.43	Torque reference maximum value <sup>①</sup>	[C3.42]...200.0 %	150.0	0.1	Run
C3.44	Torque positive limit <sup>①</sup>	0.0...200.0 %	150.0	0.1	Run
C3.45	Torque negative limit <sup>①</sup>	0.0...200.0 %	150.0	0.1	Run
C3.50	Initial angle detection current	50...150 % <sup>②</sup>	80	1	Stop
C3.51	Initial angle detection mode	0: No detection 1: Detection when first power on 2: Detection at every running	2	-	Stop

①: percentage of rated torque calculated based on frequency converter rated power.

②: percentage of motor rated current.



\*: All parameters in Group C3 are **ONLY** for Frequency Converter EFC 5610.

### 3.3.4 Group E: Function Control Parameters

#### E0: Set point and control parameters

Code	Name	Setting range	Default	Min.	Attri.
E0.00	First frequency setting source	0...99	0	-	Stop
E0.01	First run command source	0...2	0	-	Stop
E0.02	Second frequency setting source	0...99	2	-	Stop
E0.03	Second run command source	0...2	1	-	Stop
E0.04	Frequency setting source combination	0...2	0	-	Stop
E0.06	Digital setting frequency saving mode	0...3	0	-	Stop
E0.07	Digital setting frequency	0.00...[E0.09] Hz	50.00	0.01	Run
E0.08	Maximum output frequency	50.00...400.00 Hz	50.00	0.01	Stop
E0.09	Output frequency high limit	[E0.10]...[E0.08] Hz	50.00	0.01	Run
E0.10	Output frequency low limit	0.00...[E0.09] Hz	0.00	0.01	Run
E0.11	Reverse running frequency	0.00...[E0.09] Hz	0.00	0.01	Run
E0.15	Low speed running setting	0: Run with 0.00 Hz 1: Run with low limit frequency	0	-	Stop
E0.16	Low speed frequency hysteresis	0.00...[E0.10] Hz	0.00	0.01	Stop
E0.17	Direction control	0: Forward / Reverse 1: Forward only 2: Reverse only 3: Swap default direction	0	-	Stop
E0.18	Direction change dead time	0.0...60.0 s	1.0	0.1	Stop
E0.25	Acceleration / deceleration curve mode	0: Linear mode 1: S-curve	0	-	Stop
E0.26	Acceleration time	0.1...6,000.0 s	DOM	0.1	Run
E0.27	Deceleration time	0.1...6,000.0 s	DOM	0.1	Run
E0.28	S-curve starting phase factor	0.0...40.0 %	20.0	0.1	Stop
E0.29	S-curve stopping phase factor	0.0...40.0 %	20.0	0.1	Stop
E0.35	Start mode	0: Start directly 1: DC-braking before start 2: Start with speed capture 3: Automatic start / stop according to setting frequency	0	-	Stop

Code	Name	Setting range	Default	Min.	Attri.
E0.36	Start frequency	0.00...50.00 Hz	0.05	0.01	Stop
E0.37	Start frequency holding time	0.0...20.0 s	0.1	0.1	Stop
E0.38	Start DC-braking time	0.0...20.0 s (0.0: Inactive)	0.0	0.1	Stop
E0.39	Start DC-braking current <sup>①</sup>	0.0...150.0 %	0.0	0.1	Stop
E0.41	Automatic start / stop frequency threshold	0.01...[E0.09] Hz	16.00	0.01	Stop
E0.45	Power loss restart mode	0: Inactive 1: Active for panel control 2: Active only for 2-wire control	0	-	Stop
E0.46	Power loss restart delay	0.0...10.0 s	1.0	0.1	Stop
E0.50	Stop mode	0: Decelerating stop 1: Freewheeling stop 1 2: Freewheeling stop 2	0	-	Stop
E0.52	Stop DC-braking initial frequency	0.00...50.00 Hz	0.00	0.01	Stop
E0.53	Stop DC-braking time	0.0...20.0 s (0.0: Inactive)	0.0	0.1	Stop
E0.54	Stop DC-braking current <sup>①</sup>	0.0...150.0 %	0.0	0.1	Stop
E0.55	Overexcitation braking factor	1.00...1.40	1.10	0.01	Run
E0.60	Jog frequency	0.00...[E0.08] Hz	5.00	0.01	Run
E0.61	Jog acceleration time	0.1...6,000.0 s	5.0	0.1	Run
E0.62	Jog deceleration time	0.1...6,000.0 s	5.0	0.1	Run
E0.70	Skip frequency 1	0.00...[E0.09] Hz	0.00	0.01	Stop
E0.71	Skip frequency 2	0.00...[E0.09] Hz	0.00	0.01	Stop
E0.72	Skip frequency 3	0.00...[E0.09] Hz	0.00	0.01	Stop
E0.73	Skip frequency range	0.00...30.00 Hz	0.00	0.01	Stop
E0.74	Skip window acceleration factor	1...100	1	1	Stop

①: percentage of frequency converter rated current.

### Setting range of E0.00, E0.02:

0: Panel potentiometer

1: Panel button setting

2: AI1 analog input

3: AI2 analog input

- 4: EAI analog input
- 10: X5 pulse input
- 11: Digital input Up / Down command
- 20: Communication
- 21: Multi-speed settings
- 99: Inactive

**Setting range of E0.01, E0.03:**

- 0: Panel
- 1: Multi-function digital input
- 2: Communication

**Setting range of E0.04:**

- 0: No combination
- 1: First frequency setting + second frequency setting
- 2: First frequency setting - second frequency setting

**Setting range of E0.06:**

- 0: Not saved when powered off or stopped
- 1: Not saved when powered off; saved when stopped
- 2: Saved when powered off; not saved when stopped
- 3: Saved when powered off or stopped

## E1: Input terminal parameters

Code	Name	Setting range	Default	Min.	Attri.
E1.00	X1 input	0...46	35	-	Stop
E1.01	X2 input		36	-	Stop
E1.02	X3 input		0	-	Stop
E1.03	X4 input		0	-	Stop
E1.04	X5 input	0...46	0	-	Stop
E1.15	2-wire/3-wire control mode	0...4	0	-	Stop
E1.16	Digital input Up / Down change rate	0.10...100.00 Hz/s	1.00	0.01	Run
E1.17	Digital input Up / Down initial frequency	0.00...[E0.09] Hz	0.00	0.01	Run
E1.25	Pulse input maximum frequency	0.0...50.0 kHz	50.0	0.1	Run
E1.26	Pulse input filter time	0.000...2.000 s	0.100	0.001	Run
E1.35	AI1 input mode	0: 0...20 mA	2	-	Run
E1.40	AI2 input mode	1: 4...20 mA 2: 0...10 V 3: 0...5 V 4: 2...10 V	1	-	Run
E1.38	AI1 gain	0.00...10.00	1.00	0.01	Run
E1.43	AI2 gain	0.00...10.00	1.00	0.01	Run
E1.60	Motor temperature sensor channel	0: Inactive 1: AI1 analog input 2: AI2 analog input 3: EAI analog input	0	-	Stop
E1.61	Broken wire protection	0: Inactive 1: Warning 2: Error	0	-	Stop
E1.68	Analog input curve setting	0...7	0	-	Run
E1.69	Analog input filter time	0.000...2.000 s	0.100	0.001	Run
E1.70	Input curve 1 minimum	0.0 %...[E1.72]	0.0	0.1	Run
E1.71	Input curve 1 minimum frequency	0.00...[E0.09] Hz	0.00	0.01	Run
E1.72	Input curve 1 maximum	[E1.70]...100.0 %	100.0	0.1	Run
E1.73	Input curve 1 maximum frequency	0.00...[E0.09] Hz	50.00	0.01	Run
E1.75	Input curve 2 minimum	0.0 %...[E1.77]	0.0	0.1	Run
E1.76	Input curve 2 minimum frequency	0.00...[E0.09] Hz	0.00	0.01	Run

Code	Name	Setting range	Default	Min.	Attri.
E1.77	Input curve 2 maximum	[E1.75]...100.0 %	100.0	0.1	Run
E1.78	Input curve 2 maximum frequency	0.00...[E0.09] Hz	50.00	0.01	Run

### Setting range of E1.00...E1.03 (0...41), E1.04 (0...47):

0: Inactive

1: Multi-speed control input 1

2: Multi-speed control input 2

3: Multi-speed control input 3

4: Multi-speed control input 4

10: Acceleration / deceleration time 1 activation

11: Acceleration / deceleration time 2 activation

12: Acceleration / deceleration time 3 activation

15: Freewheeling stop activation

16: Stop DC-braking activation

20: Frequency Up command

21: Frequency Down command

22: Up / Down command reset

23: Torque / speed control switch

25: 3-wire control

26: Simple PLC stop

27: Simple PLC pause

30: Second frequency setting source activation

31: Second run command source activation

32: Error signal N.O. contact input

33: Error signal N.C. contact input

34: Error reset

35: Forward running (FWD)

36: Reverse running (REV)

37: Forward jog

38: Reverse jog

39: Counter input

40: Counter reset

41: PID deactivation

46: User parameter set selection

47: Pulse input mode activation

**Setting range of E1.15:**

- 0: 2-wire forward / stop, reverse / stop
- 1: 2-wire forward / reverse, run / stop
- 2: 3-wire control mode 1
- 3: 3-wire control mode 2
- 4: 1-wire control

**Setting range of E1.68:**

- 0: Curve1 for AI1, curve1 for AI2, curve1 for pulse input
- 1: Curve2 for AI1, curve1 for AI2, curve1 for pulse input
- 2: Curve1 for AI1, curve2 for AI2, curve1 for pulse input
- 3: Curve2 for AI1, curve2 for AI2, curve1 for pulse input
- 4: Curve1 for AI1, curve1 for AI2, curve2 for pulse input
- 5: Curve2 for AI1, curve1 for AI2, curve2 for pulse input
- 6: Curve1 for AI1, curve2 for AI2, curve2 for pulse input
- 7: Curve2 for AI1, curve2 for AI2, curve2 for pulse input

## E2: Output terminal parameters

Code	Name	Setting range	Default	Min.	Attri.
E2.01	DO1 output setting	0...99	1	-	Stop
E2.02	DO1 pulse output setting	0: Converter output frequency 1: Converter output voltage 2: Converter output current 99: Inactive	0	-	Stop
E2.03	Pulse output maximum frequency	0.1...32.0 kHz	32.0	0.1	Run
E2.15	Relay1 output selection	0...99	1	-	Stop
E2.25	AO1 output mode	0: 0...10 V 1: 0...20 mA	0	-	Run
E2.26	AO1 output setting	0: Output frequency 1: Setting frequency 2: Output current 4: Output voltage 5: Output power 6: AI1 analog input 7: AI2 analog input 8: EAI analog input 11: Motor temperature sensor power supply 99: Inactive	0	-	Run
E2.27	AO1 gain	0.00...10.00	1.00	0.01	Run
E2.40	Rated voltage	1P 200...240 VAC	220	1	Stop
		3P 380...480 VAC	380		
E2.50	Output curve 1 minimum	0.0 %...[E2.52]	0.0	0.1	Run
E2.51	Output curve 1 minimum value	0.00...100.00 %	0.00	0.01	Run
E2.52	Output curve 1 maximum	[E2.50]...100.0 %	100.0	0.1	Run
E2.53	Output curve 1 maximum value	0.00...100.00 %	100.00	0.01	Run
E2.70	Frequency detection width	0.00...400.00 Hz	2.50	0.01	Run
E2.71	Frequency detection level FDT1	0.01...400.00 Hz	50.00	0.01	Run
E2.72	Frequency detection level FDT1 width	0.01...[E2.71] Hz	1.00	0.01	Run
E2.73	Frequency detection level FDT2	0.01...400.00 Hz	25.00	0.01	Run



Code	Name	Setting range	Default	Min.	Attri.
E2.74	Frequency detection level FDT2 width	0.01...[E2.73] Hz	1.00	0.01	Run
E2.80	Counter middle value	0...[E2.81]	0	1	Run
E2.81	Counter target value	[E2.80]...9,999	0	1	Run

### Setting range of E2.01 (0...19) and E2.15 (0...18):

- 0: Converter ready
- 1: Converter running
- 2: Converter DC-braking
- 3: Converter running at zero speed
- 4: Speed arrival
- 5: Frequency level detection signal (FDT1)
- 6: Frequency level detection signal (FDT2)
- 7: Simple PLC stage complete
- 8: Simple PLC cycle complete
- 10: Converter undervoltage
- 11: Converter overload pre-warning
- 12: Motor overload pre-warning
- 13: Converter stop by external error
- 14: Converter error
- 15: Converter OK
- 16: Counter target value arrival
- 17: Counter middle value arrival
- 18: PID reference engineering value arrival
- 19: Pulse output mode enable(only available with DO1 output selection)
- 20: Torque control mode
- 99: Inactive

**E3: Multi-speed and simple PLC parameters**

Code	Name	Setting range	Default	Min.	Attri.
E3.00	Simple PLC running mode	0: Inactive 1: Stop after selected cycle 2: Continuously cycling 3: Run last stage after selected cycle	0	-	Stop
E3.01	Simple PLC time multiplier	1...60	1	1	Stop
E3.02	Simple PLC cycle number	1...1,000	1	1	Stop
E3.10	Acceleration time 2	0.1...6,000.0 s	10.0	0.1	Run
E3.11	Deceleration time 2	0.1...6,000.0 s	10.0	0.1	Run
E3.12	Acceleration time 3	0.1...6,000.0 s	10.0	0.1	Run
E3.13	Deceleration time 3	0.1...6,000.0 s	10.0	0.1	Run
E3.14	Acceleration time 4	0.1...6,000.0 s	10.0	0.1	Run
E3.15	Deceleration time 4	0.1...6,000.0 s	10.0	0.1	Run
E3.16	Acceleration time 5	0.1...6,000.0 s	10.0	0.1	Run
E3.17	Deceleration time 5	0.1...6,000.0 s	10.0	0.1	Run
E3.18	Acceleration time 6	0.1...6,000.0 s	10.0	0.1	Run
E3.19	Deceleration time 6	0.1...6,000.0 s	10.0	0.1	Run
E3.20	Acceleration time 7	0.1...6,000.0 s	10.0	0.1	Run
E3.21	Deceleration time 7	0.1...6,000.0 s	10.0	0.1	Run
E3.22	Acceleration time 8	0.1...6,000.0 s	10.0	0.1	Run
E3.23	Deceleration time 8	0.1...6,000.0 s	10.0	0.1	Run
E3.40	Multi-speed frequency 1	0.00...[E0.09] Hz	0.00	0.01	Run
E3.41	Multi-speed frequency 2	0.00...[E0.09] Hz	0.00	0.01	Run
E3.42	Multi-speed frequency 3	0.00...[E0.09] Hz	0.00	0.01	Run
E3.43	Multi-speed frequency 4	0.00...[E0.09] Hz	0.00	0.01	Run
E3.44	Multi-speed frequency 5	0.00...[E0.09] Hz	0.00	0.01	Run
E3.45	Multi-speed frequency 6	0.00...[E0.09] Hz	0.00	0.01	Run
E3.46	Multi-speed frequency 7	0.00...[E0.09] Hz	0.00	0.01	Run
E3.47	Multi-speed frequency 8	0.00...[E0.09] Hz	0.00	0.01	Run
E3.48	Multi-speed frequency 9	0.00...[E0.09] Hz	0.00	0.01	Run
E3.49	Multi-speed frequency 10	0.00...[E0.09] Hz	0.00	0.01	Run
E3.50	Multi-speed frequency 11	0.00...[E0.09] Hz	0.00	0.01	Run
E3.51	Multi-speed frequency 12	0.00...[E0.09] Hz	0.00	0.01	Run
E3.52	Multi-speed frequency 13	0.00...[E0.09] Hz	0.00	0.01	Run
E3.53	Multi-speed frequency 14	0.00...[E0.09] Hz	0.00	0.01	Run

Code	Name	Setting range	Default	Min.	Attri.
E3.54	Multi-speed frequency 15	0.00...[E0.09] Hz	0.00	0.01	Run
E3.59	Stage 0 frequency source	0: Digital setting frequency 1: AI1 analog input 2: AI2 analog input 3: EAI analog input 4: X5 pulse input 5: Communication	0	-	Stop
E3.60	Stage 0 action		011	-	Stop
E3.62	Stage 1 action	011, 012, 013, 014, 015, 016, 017, 018, 021, 022, 023, 024, 025, 026, 027, 028, 031, 032, 033, 034, 035, 036, 037, 038, 041, 042, 043, 044, 045, 046, 047, 048, 051, 052, 053, 054, 055, 056, 057, 058, 061, 062, 063, 064, 065, 066, 067, 068, 071, 072, 073, 074, 075, 076, 077, 078, 081, 082, 083, 084, 085, 086, 087, 088, 111, 112, 113, 114, 115, 116, 117, 118, 121, 122, 123, 124, 125, 126, 127, 128, 131, 132, 133, 134, 135, 136, 137, 138, 141, 142, 143, 144, 145, 146, 147, 148, 151, 152, 153, 154, 155, 156, 157, 158, 161, 162, 163, 164, 165, 166, 167, 168, 171, 172, 173, 174, 175, 176, 177, 178, 181, 182, 183, 184, 185, 186, 187, 188	011	-	Stop
E3.64	Stage 2 action		011	-	Stop
E3.66	Stage 3 action		011	-	Stop
E3.68	Stage 4 action		011	-	Stop
E3.70	Stage 5 action		011	-	Stop
E3.72	Stage 6 action		011	-	Stop
E3.74	Stage 7 action		011	-	Stop
E3.76	Stage 8 action		011	-	Stop
E3.78	Stage 9 action		011	-	Stop
E3.80	Stage 10 action		011	-	Stop
E3.82	Stage 11 action		011	-	Stop
E3.84	Stage 12 action		011	-	Stop
E3.86	Stage 13 action		011	-	Stop
E3.88	Stage 14 action		011	-	Stop
E3.90	Stage 15 action		011	-	Stop
E3.61	Stage 0 running time	0.0...6,000.0 s	20.0	0.1	Stop
E3.63	Stage 1 running time	0.0...6,000.0 s	20.0	0.1	Stop
E3.65	Stage 2 running time	0.0...6,000.0 s	20.0	0.1	Stop
E3.67	Stage 3 running time	0.0...6,000.0 s	20.0	0.1	Stop
E3.69	Stage 4 running time	0.0...6,000.0 s	20.0	0.1	Stop
E3.71	Stage 5 running time	0.0...6,000.0 s	20.0	0.1	Stop
E3.73	Stage 6 running time	0.0...6,000.0 s	20.0	0.1	Stop
E3.75	Stage 7 running time	0.0...6,000.0 s	20.0	0.1	Stop
E3.77	Stage 8 running time	0.0...6,000.0 s	20.0	0.1	Stop
E3.79	Stage 9 running time	0.0...6,000.0 s	20.0	0.1	Stop
E3.81	Stage 10 running time	0.0...6,000.0 s	20.0	0.1	Stop
E3.83	Stage 11 running time	0.0...6,000.0 s	20.0	0.1	Stop
E3.85	Stage 12 running time	0.0...6,000.0 s	20.0	0.1	Stop

Code	Name	Setting range	Default	Min.	Attri.
E3.87	Stage 13 running time	0.0...6,000.0 s	20.0	0.1	Stop
E3.89	Stage 14 running time	0.0...6,000.0 s	20.0	0.1	Stop
E3.91	Stage 15 running time	0.0...6,000.0 s	20.0	0.1	Stop

**E4: PID control parameters**

Code	Name	Setting range	Default	Min.	Attri.
E4.00	PID reference channel	0...9	0	-	Stop
E4.01	PID feedback channel	0: AI1 analog input 1: AI2 analog input 2: X5 pulse input 3: EAI analog input 99: Inactive	0	-	Stop
E4.02	PID reference / feedback factor	0.01...100.00	1.00	0.01	Run
E4.03	PID engineering analog reference	0.00...10.00	0.00	0.01	Run
E4.04	PID engineering speed reference	0...30,000 rpm	0	1	Run
E4.05	PID feedback polarity	0: Positive 1: Negative	0	-	Stop
E4.15	Proportional gain - P	0.000...60.000	1.500	0.001	Run
E4.16	Integral time - Ti	0.00...100.00 s (0.00: no integral)	1.50	0.01	Run
E4.17	Derivative time - Td	0.00...100.00 s (0.00: no derivative)	0.00	0.01	Run
E4.18	Sampling period - T	0.01...100.00 s	0.50	0.01	Run
E4.19	PID feed forward dynamic limit	0.00...100.00 %	10.00	0.01	Run
E4.20	PID feed forward minimum value	0.00...100.00 %	0.00	0.01	Run
E4.30	PID deadband	0.0...20.0 %	2.0	0.1	Run
E4.31	PID regulation mode	0, 1	0	-	Run
E4.32	PID engineering value detection width	0.01...100.00	1.00	0.01	Run
E4.33	PID feedforward settings	0: Inactive 1: Active	0	-	Stop

**Setting range of E4.00:**

- 0: Inactive; 1: Panel potentiometer  
 2: Panel button; 3: AI1 analog input  
 4: AI2 analog input; 5: X5 pulse input  
 6: EAI analog input; 7: Communication  
 8: Analog reference E4.03; 9: Speed reference E4.04

**Setting range of E4.31:**

- 0: Stop integral regulation when frequency arrives at upper / lower limit  
 1: Continue integral regulation when frequency arrives at upper / lower limit

**E5: Extended function parameters**

Code	Name	Setting range	Default	Min.	Attri.
E5.01	High resolution output current filter time	5...500 ms	40	1	Run
E5.02	User-defined speed scaling factor	0.01...100.00	1.00	0.01	Run
E5.05	Pump dry protection threshold	0.0%...[E5.08]	30.0	0.1	Run
E5.06	Pump dry protection delay	0.0...300.0 s (0.0: Inactive)	0.0	0.1	Run
E5.07	Pump dry protection delay at start-up	0.0...300.0 s	30.0	0.1	Run
E5.08	Pump leakage protection threshold	0.0...100.0%	50.0	0.1	Run
E5.09	Pump leakage protection delay	0.0...600.0 s (0.0: Inactive)	0.0	0.1	Run
E5.10	Pump leakage protection delay at start-up	0.0...600.0 s	60.0	0.1	Run
E5.15	Sleep level	0.00...[E0.09] Hz	0.00	0.01	Run
E5.16	Sleep delay	0.0...3,600.0 s	60.0	0.1	Run
E5.17	Sleep boost time	0.0...3,600.0 s	0.0	0.1	Run
E5.18	Sleep boost amplitude	0.0...100.0%	0.0	0.1	Run
E5.19	Wake up level	0.0...100.0%	0.0	0.1	Run
E5.20	Wake up delay	0.2...60.0 s	0.5	0.1	Run

**E8: Standard communication parameters**

Code	Name	Setting range	Default	Min.	Attri.
E8.00	Communication protocol	0: Modbus 1: Extension card	0	-	Stop
E8.01	Communication error detection time	0.0...60.0 s (0.0: Inactive)	0.0	0.1	Stop
E8.02	Communication error protection mode	0: Freewheeling stop 1: Keep running	1	-	Stop
E8.03	Communication process data loss behavior	0: Decelerating stop 1: Freewheeling stop 2: Keep running	0	-	Stop
E8.10	Modbus baud rate	0: 1,200 bps 1: 2,400 bps 2: 4,800 bps 3: 9,600 bps 4: 19,200 bps 5: 38,400 bps	3	-	Stop
E8.11	Modbus data format	0...3	0	-	Stop
E8.12	Modbus local address	1...247	1	1	Stop
E8.13	Modbus level / edge sensitivity selection	0: Level sensitive 1: Edge sensitive	1	-	Stop

**Setting range of E8.11:**

- 0: N, 8, 1 (1 start bit, 8 data bits, 1 Stop bit, no parity)
- 1: E, 8, 1 (1 start bit, 8 data bits, 1 Stop bit, even parity)
- 2: O, 8, 1 (1 start bit, 8 data bits, 1 Stop bit, odd parity)
- 3: N, 8, 2 (1 start bit, 8 data bits, 2 Stop bits, no parity)

**E9: Protection and error parameters**

Code	Name	Setting range	Default	Min.	Attri.
E9.00	Automatic error reset attempts	0...3 (0: Inactive)	0	-	Stop
E9.01	Automatic error reset interval	0.1...60.0 s	10.0	0.1	Stop
E9.05	Last error type	-	-	-	Read
E9.06	Second last error type	-	-	-	Read
E9.07	Third last error type	-	-	-	Read
E9.10	Output frequency at last error	-	-	0.01	Read
E9.11	Setting frequency at last error	-	-	0.01	Read
E9.12	Output current at last error	-	-	0.1	Read
E9.13	Output voltage at last error	-	-	1	Read
E9.14	DC-bus voltage at last error	-	-	1	Read
E9.15	Power module temperature at last error	-	-	1	Read

**Value range of E9.05...E9.07:**

0: No error

- 1: OC-1, overcurrent at constant speed
- 2: OC-2, overcurrent during acceleration
- 3: OC-3, overcurrent during deceleration
- 4: OE-1, overvoltage at constant speed
- 5: OE-2, overvoltage during acceleration
- 6: OE-3, overvoltage during deceleration
- 7: OE-4, overvoltage during stop
- 8: UE-1, undervoltage during run
- 9: SC, surge current or short circuit
- 10: IPH.L, input phase loss
- 11: OPH.L, output phase loss
- 12: ESS-, soft start error
- 20: OL-1, converter overload
- 21: OH, converter over temperature
- 22: UH, converter under temperature
- 23: FF, fan failure
- 24: Pdr, pump dry
- 25: CoL-, command value lost
- 30: OL-2, motor overload



- 31: Ot, motor over temperature
- 32: t-Er, motor parameter tuning error
- 33: AdE-, synchronous motor angle detection error
- 38: AibE, analog input broken wire detection
- 39: EPS-, DC\_IN power supply error
- 40: dir1, forward running lock error
- 41: dir2, reverse running lock error
- 42: E-St, terminal error signal
- 43: FFE-, firmware version mismatch
- 44: rS-, Modbus communication error
- 45: E.Par, parameter settings invalid
- 46: U.Par, unknown parameter restore error
- 48: idA-, internal communication error
- 49: idP-, internal parameter error
- 50: idE-, converter internal error
- 51: OCd-, extension card internal error
- 52: OCC, extension card PDOs configuration error
- 54: PcE-, remote control communication error
- 55: PbrE, parameter backup / restore error
- 56: PrEF, parameter restore error after firmware update
- 60: APP-, application firmware error
- 61: APE1, application error 1
- 62: APE2, application error 2
- 63: APE3, application error 3
- 64: APE4, application error 4
- 65: APE5, application error 5

### 3.3.5 Group F0: APP Parameters

Code	Name	Setting range	Default	Min.	Attri.
F0.01	APP version	-	-	-	Read
F0.02	APP identifier	0x0001 ... 0x0FFF	-	-	Read
F0.03	APP API required version	-	-	-	Read
F0.06	APP trial time left	0...65,535	-	-	Read
F0.07	APP API version	-	-	-	Read
F0.10	APP status	0x0000H...0xFFFFH	-	1	Read

### 3.3.6 Group H: Extension Card Parameters

#### H0: Extension card general parameters

Code	Name	Setting range	Default	Min.	Attri.
H0.00	Control word	00000...0FFFF	00000	1	Run
H0.01	Status word	-	00000	-	Read
H0.10	Frequency command	0.00...655.35	0.00	0.01	Run
H0.18	Opt 1 active interface version	-	-	0.01	Read
H0.19	Opt 2 active interface version	-	-	0.01	Read
H0.20	Extension card 1 type	0: None	0	-	Read
H0.30	Extension card 2 type	1: PROFIBUS card 2: CANopen card 3: Multi-Ethernet card 8: I/O card 9: Relay card	0	-	Read
H0.23	Extension card 1 firmware version	-	-	0.01	Read
H0.33	Extension card 2 firmware version	-	-	0.01	Read

## H1: Communication card parameters

Code	Name	Setting range	Default	Min.	Attri.	
H1.00	PROFIBUS local address	0...126	1	1	Stop	
H1.01	Present baud rate	0: None 1: 9.6 kbps 2: 19.2 kbps 3: 45.45 kbps 4: 93.75 kbps 5: 187.5 kbps 6: 500 kbps 7: 1,500 kbps 8: 3,000 kbps 9: 6,000 kbps 10: 12,000 kbps	-	-	Read	
H1.02	Present telegram type	1: PPO1 2: PPO2 3: PPO3 4: PPO4 5: PPO5 6: PPO6 7: PPO7 8: PPO8	-	-	Read	
H1.10	Output PZD 1		1	1	Stop	
H1.11	Output PZD 2		2	1	Stop	
H1.12	Output PZD 3		0	1	Stop	
H1.13	Output PZD 4		0: Not used	0	1	Stop
H1.14	Output PZD 5		1: Control word	0	1	Stop
H1.15	Output PZD 6		2: Frequency command	0	1	Stop
H1.16	Output PZD 7		3: Torque command	0	1	Stop
H1.17	Output PZD 8		0	1	Stop	
H1.18	Output PZD 9		0	1	Stop	
H1.19	Output PZD 10		0	1	Stop	

Code	Name	Setting range	Default	Min.	Attri.
H1.30	Input PZD 1	0: Not used 1: Status word 100: d0.00 (Output frequency) 101...199: d0.01...d0.99 (Monitoring values)	1	1	Stop
H1.31	Input PZD 2		100	1	Stop
H1.32	Input PZD 3		0	1	Stop
H1.33	Input PZD 4		0	1	Stop
H1.34	Input PZD 5		0	1	Stop
H1.35	Input PZD 6		0	1	Stop
H1.36	Input PZD 7		0	1	Stop
H1.37	Input PZD 8		0	1	Stop
H1.38	Input PZD 9		0	1	Stop
H1.39	Input PZD 10		0	1	Stop

## H8: I/O card parameters

Code	Name	Setting range	Default	Min.	Attri.
H8.00	EX1 input	0...41	0	-	Stop
H8.01	EX2 input		0	-	Stop
H8.02	EX3 input		0	-	Stop
H8.03	EX4 input		0	-	Stop
H8.05	EAI input mode	0: 0...20 mA 1: 4...20 mA 2: 0...10 V 3: 0...5 V 4: 2...10 V 5: -10...10 V	0	-	Stop
H8.06	EAI input polarity setting	0...2	1	-	Stop
H8.08	EAI curve selection	0: Curve 0 1: Curve 1 2: Curve 2	1	-	Stop
H8.09	EAI filter time	0.000...2.000	0.100	0.001	Run
H8.10	EAI gain	0.00...10.00	1.00	0.01	Run
H8.15	Input curve 0 minimum	0.0 ...100.0 %	100.0	0.1	Run
H8.16	Input curve 0 minimum frequency	0.00...[E0.09]	0.00	0.01	Run
H8.17	Input curve 0 maximum	0.0...100.0 %	100.0	0.1	Run
H8.18	Input curve 0 maximum frequency	0.00...[E0.09]	0.00	0.01	Run
H8.20	EDO output setting	0...20	1	-	Stop
H8.21	Extended relay output selection		1	-	Stop
H8.25	EAO output mode	0: 0...10 V 1: 0...20 mA	0	-	Run
H8.26	EAO output selection	0: Running frequency 1: Set frequency 2: Output current 4: Output voltage 5: Output power 6: AI1 analog input 7: AI2 analog input 8: EAI analog input 11: Motor temperature sensor power	0	-	Run

Code	Name	Setting range	Default	Min.	Attri.
H8.27	EAO gain	0.00...10.00	1.00	0.01	Run
H8.87	I/O card self test	0: Inactive 1: EAO test 2: EDO test 3: ERO test 4: Total test	1	-	Stop

**Setting range of H8.00...H8.03:**

- 0: No function assigned
- 1: Multi-speed control input 1
- 2: Multi-speed control input 2
- 3: Multi-speed control input 3
- 4: Multi-speed control input 4
- 10: Acceleration/deceleration time 1 activation
- 11: Acceleration/deceleration time 2 activation
- 12: Acceleration/deceleration time 3 activation
- 15: Freewheeling stop activation
- 16: Stop DC-braking activation
- 20: Frequency Up command
- 21: Frequency Down command
- 22: Up/Down command reset
- 23: Torque/Speed control switch
- 25: 3-wire control
- 26: Simple PLC stop
- 27: Simple PLC pause
- 30: Second frequency setting source activation
- 31: Second run command source activation
- 32: Error signal N.O. contact input
- 33: Error signal N.C. contact input
- 34: Error reset
- 35: Forward running (FWD)
- 36: Reverse running (REV)
- 37: Forward jog
- 38: Reverse jog
- 39: Counter input
- 40: Counter reset

41: PID deactivation

**Setting range of H8.06:**

0: Polarity inactive

1: Polarity active without direction control

2: Polarity active with direction control

**Setting range of H8.20, H8.21:**

0: Converter ready

1: Converter running

2: Converter DC-braking

3: Converter running at zero speed

4: Speed arrival

5: Frequency level detection signal (FDT1)

6: Frequency level detection signal (FDT2)

7: Simple PLC stage complete

8: Simple PLC cycle complete

10: Converter undervoltage

11: Converter overload pre-warning

12: Motor overload pre-warning

13: Converter stop by external error

14: Converter error

15: Converter OK

16: Counter target value arrival

17: Counter middle value arrival

18: PID reference engineering value arrival

20: Torque control mode



**H9: Relay card parameters**

Code	Name	Setting range	Default	Min.	Attri.
H9.00	Extended relay 1 output selection	0...20	0	–	Stop
H9.01	Extended relay 2 output selection		0	–	Stop
H9.02	Extended relay 3 output selection		0	–	Run
H9.03	Extended relay 4 output selection		0	–	Run
H9.97	Relay card self test	0: Inactive 1: R1 test 2: R2 test 3: R3 test 4: R4 test 5: Total test	0	–	Stop

**Setting range of H9.00...H9.03:**

- 0: Converter ready
- 1: Converter running
- 2: Converter DC-braking
- 3: Converter running at zero speed
- 4: Speed arrival
- 5: Frequency level detection signal (FDT1)
- 6: Frequency level detection signal (FDT2)
- 7: Simple PLC stage complete
- 8: Simple PLC cycle complete
- 10: Converter undervoltage
- 11: Converter overload pre-warning
- 12: Motor overload pre-warning
- 13: Converter stop by external error
- 14: Converter error
- 15: Converter OK
- 16: Counter target value arrival
- 17: Counter middle value arrival
- 18: PID reference engineering value arrival
- 20: Torque control mode

### 3.3.7 Group U: Panel Parameters

#### U0: General panel parameters

Code	Name	Setting range	Default	Min.	Attri.
U0.00	Direction control by panel	0: Forward; 1: Reverse	0	–	Run
U0.01	Stop button control	0: Active only for panel control 1: Valid for all control methods	1	–	Run
U0.99	Panel firmware version	00.00...99.99	–	0.01	Read

#### U1: LED panel parameters

Code	Name	Setting range	Default	Min.	Attri.
U1.00	Run monitoring display	0...99	0	–	Run
U1.10	Stop monitoring display		2	–	Run

0: Output frequency

1: Actual speed

2: Setting frequency

3: Setting speed

4: User-defined setting speed

5: User-defined actual speed

10: Output voltage

11: Output current

12: Output power

13: DC-bus voltage

16: Output torque

17: Setting torque

20: Power module temperature

21: Actual carrier frequency

23: Power stage running time

30: AI1 input

31: AI2 input

33: I/O card EAI input

35: AO1 output

37: I/O card EAO output

40: Digital input 1

43: I/O card digital input

45: DO1 output  
47: I/O card EDO output  
50: Pulse input frequency  
55: Pulse output frequency  
60: Relay output  
62: I/O card relay output  
63: Relay card output  
70: PID reference engineering value  
71: PID feedback engineering value  
80: APP Display00  
81: APP Display01  
98: High resolution output current  
99: Firmware version

### 3.3.8 Group d0: Monitoring Parameters

Code	Name	Minimum unit
d0.00	Output frequency	0.01 Hz
d0.01	Actual speed	1 rpm
d0.02	Setting frequency	0.01 Hz
d0.03	Setting speed	1 rpm
d0.04	User-defined setting speed	0.1
d0.05	User-defined output speed	0.1
d0.10	Output voltage	1 V
d0.11	Output current	0.1 A
d0.12	Output power	0.1 kW
d0.13	DC-bus voltage	1 V
d0.16	Output torque	0.1 %
d0.17	Setting torque	0.1 %
d0.20	Power module temperature	1 °C
d0.21	Actual carrier frequency	1 kHz
d0.23	Power stage running time	1 h
d0.30	AI1 input	0.01 V / 0.01 mA
d0.31	AI2 input	0.01 V / 0.01 mA
d0.33	I/O card EAI input	0.01 V / 0.01 mA
d0.35	AO1 output	0.01 V / 0.01 mA
d0.37	I/O card EAO output	0.01 V / 0.01 mA
d0.40	Digital input 1	–
d0.43	I/O card digital input	–
d0.45	DO1 output	–
d0.47	I/O card EDO output	–
d0.50	Pulse input frequency	0.01 kHz
d0.55	Pulse output frequency	0.1 kHz
d0.60	Relay output	–
d0.62	I/O card relay output	–
d0.63	Relay card output	–
d0.70	PID reference engineering value	0.1
d0.71	PID feedback engineering value	0.1
d0.80	APP Display00	–
d0.81	APP Display01	–
d0.98	High resolution output current	0.01 A
d0.99	Firmware version	0.01

## 4 Diagnosis

### 4.1 Display of LED Characters

<b>Character</b>	A	b	C	d	E	F	H	I	L
<b>Display</b>									
<b>Character</b>	n	O	o	P	r	S	t	U	-
<b>Display</b>									

Tab. 4-1: Display of LED characters

### 4.2 Status Code

<b>Code</b>	<b>Description</b>
8.8.8.8.8.	Displayed at power on, detecting the operating panel
''''''''''''''''''''	During parameter backup...
tUnE	Motor parameter tuning
PSLP	PID sleeping
-PF-	Modified parameters which are different from default value
-EP-	Parameters with invalid settings
PAr1	Parameter set switching from set 2 to set 1
PAr2	Parameter set switching from set 1 to set 2

### 4.3 Warning Code

<b>Code</b>	<b>Description</b>
P.oFF	Displayed only at power down / drop in stop state
S.Err	Parameter change blocked
C-dr	Communication disconnection
PrSE	Parameter setting contradiction
FLE	Fan maintenance period expired
noCP	No modified parameter
PLE	Pump leakage
Aib-	Analog input broken wire detection
OCi	Communication data exceeds value range
Fdi	Fieldbus process data invalid

<b>Code</b>	<b>Description</b>
APF1	Warning which can be thrown by the application, description in application manual
APF2	
APF3	
APF4	
APF5	

## 4.4 Error Code

Nr. Code	Name	Description
1	OC-1	Overcurrent at constant speed
2	OC-2	Overcurrent during acceleration
3	OC-3	Overcurrent during deceleration
4	OE-1	Overvoltage at constant speed
5	OE-2	Overvoltage during acceleration
6	OE-3	Overvoltage during deceleration
7	OE-4	Overvoltage during stop
8	UE-1	Undervoltage during run
9	SC	Surge current or short circuit
10	IPH.L	Input phase loss
11	OPH.L	Output phase loss
12	ESS-	Soft start error
20	OL-1	Converter overload
21	OH	Converter over temperature
22	UH	Converter under temperature
23	FF	Fan failure
24	Pdr	Pump dry
25	CoL-	Command value lost
30	OL-2	Motor overload
31	Ot	Motor over temperature
32	t-Er	Motor parameter tuning error
33	AdE-	Synchronous motor angle detection error
38	AibE	Analog input broken wire detection
39	EPS-	DC_IN power supply error
40	dir1	Forward running lock error
41	dir2	Reverse running lock error
42	E-St	Terminal error signal
43	FFE-	Firmware version mismatch
44	rS-	Modbus communication error

Nr. Code	Name	Description
45 E.Par	Parameter settings invalid	Parameter settings are invalid after firmware update or extension card removed
46 U.Par	Unknown parameter restore error	An unknown parameter is skipped during parameter restore
48 idA-	Internal communication error	Internal error caused by communication between control boards
49 idP-	Internal parameter error	Internal error caused by parameter handling
50 idE-	Converter internal error	Converter has internal error, contact with service
51 OCd-	Extension card internal error	Extension card was successfully detected by the device at startup, but the communication failed afterwards
52 OCc	Extension card PDOs configuration error	Process data configuration error for field bus communication
54 PcE-	Remote control communication error	Error if communication to IndraWorks/ConverterWorks is lost during remote control
55 PbrE	Parameter backup / restore error	Error occurs during parameter backup and restore operation
56 PrEF	Parameter restore error after firmware update	Error occurs if parameter settings cannot be restored after firmware update
60 APP-	Application firmware error	Error message if the application firmware was not loaded correctly or trial use is over
61 APE1	Application error 1	Error which can be thrown by the application, description in application manual
62 APE2	Application error 2	
63 APE3	Application error 3	
64 APE4	Application error 4	
65 APE5	Application error 5	







## Notes

**Bosch Rexroth (Xi'an)**

Electric Drives and Controls Co., Ltd.

No. 3999, Shangji Road,

Economic and Technological Development  
Zone, 710021 Xi'an, P.R. China

Phone +49 9352 40 5060

Fax +49 9352 18 4941

service.svc@boschrexroth.de

www.boschrexroth.com



R912005856